

Q.Sonic[®] plus

Multi-Path Ultrasonic Gas Meter for Custody Transfer Measurement

Brief information

The ultrasonic gas flow meter Q.Sonic^{plus} is a six-path meter covered by an 'enhanced' Elster-Instromet patent, with extended functionality, bringing about new benefits for the end user, along with greater processing power that yields a lower measurement uncertainty.

The patented path configuration—a fully symmetrical layout of four swirl paths with double reflection and two single reflection paths—enables the measurement of both swirl and asymmetry, resulting in previously unequalled profile recognition and diagnostic possibilities.

Another innovation of the Q.Sonic^{plus} is that it can be equipped with an internal pressure and temperature measurement function. This means that the device measures both the gas pressure and temperature of the measuring tube. On the one hand, these measurements allow for a more accurate calculation of the Reynolds number for the flow profile analysis and on the other, they can be used to correct the meter body diameter and path geometry. This is useful if the process conditions differ massively from the conditions during the calibration process since both high pressure and high temperatures result in an increase in the tube cross-section and a change in path lengths and angles.

Encrypted data is managed by the real time operating system (RTOS) philosophy pioneered by Green Hills Software. Integrity RTOS provides one of the most reliable operating platforms in the world delivering piece of mind with the highest security level that is currently achievable for a real time operating system.

The electronics are located in a flame-proof housing with a separate connection compartment for field wiring. Thanks to its modular hardware design with a free slot, the device is also prepared to tackle future requirements. For user operation the system is equipped with a graphical user interface with touch screen functionality.

SonicExplorer, a PC based software package, for the operator, service, technician and engineering world is used to configure, diagnose, and monitor the Q.Sonic^{plus} flow meter either local or remote.

(cont. on next page)



FEATURES & BENEFITS

Main Features

- 6-path reflective technology
- Sizes 3" to 36"—larger sizes available upon request (DN 80 to DN 900)
- Pressure ratings ANSI class 150 to 900 PN on request
- All-metal-encapsulated intrinsically safe transducers
- Internal temperature sensor
- Flow profile detection with swirl and asymmetry measurement
- No moving parts
- No pressure drop
- Bi-directional measurement
- SonicExplorer PC software for configuration, diagnostics and health care
- OIML R137-1 compliant
- AGA 9 compliant
- MID approved.

Options

- VDSL range extender for high-speed communication (TCP/IP)
- Pressure sensor for Reynolds corrections
- Retraction tool for transducer exchange 'under pressure.'

Applications

- Custody transfer measurement of natural gas
- Gas exploration, transmission and distribution.

(cont. from previous page)

One of the unique features of SonicExplorer is the “create customer service pack”. At the sign of any warning or alarm the operator can initiate SonicExplorer to immediately collect a log containing the entire state of the ultrasonic flow meter including all diagnostics, configuration and spectral noise analysis. The customer service pack is automatically compressed, and directed to a preselected e-mail recipient for support from Honeywell Elster or Engineer/Technician of your choice.

Path Configuration

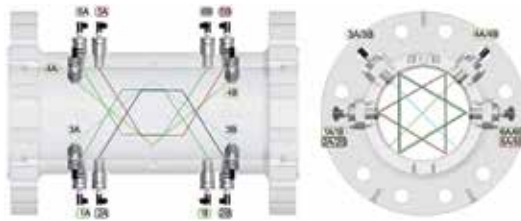

The Q.SonicPlus uses two pairs of double and two single reflection paths. Taking the mean value of both pairs will result in a symmetrically weighted measurement.

The subtraction of the paired paths provides an indication of asymmetric flow along the mirror plane of the paths as an additional diagnostic feature.

Ultrasonic Transducers Model NG

The transducers are all-metal encapsulated with titanium, which offers a smooth surface to minimize contamination. The ultrasonic frequency of 200 kHz ensures a good balance between resolution and attenuation/propagation of the signal.

Transducer Path	
Path No.	Path Type
1A/1B	Swirl path (B1-CW*)
2A/2B	Swirl path (B1-CCW**)
3A/3B	Axial path (A1)
4A/4B	Axial path (A2)
5A/5B	Swirl path (B2-CW)
6A/6B	Swirl path (B2-CCW)

*clockwise
**counter-clockwise

Components on the Meter Body

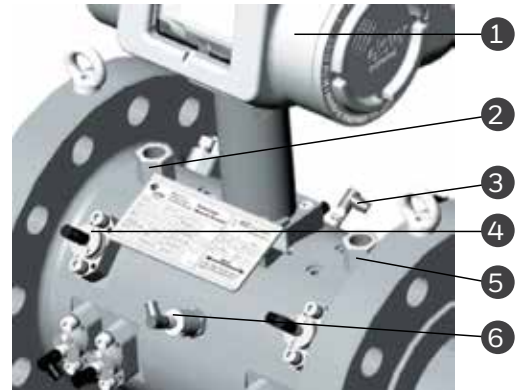

- ① Signal processing unit (SPU)
- ② Pressure connection point for external transmitter
- ③ Temperature sensor for meter body temperature
- ④ Transducer with mounting plate, prepared for retraction under pressure
- ⑤ Second pressure connection point
- ⑥ Optional pressure sensor for geometry correction and line density estimation (profile correction)

Signal Processing Unit (SPU) Series 6

The SPU electronic resides in a flame-proof



housing with a separate compartment for the terminal connections.

The boards are mounted in a

card cage with one free slot for future extensions.

A colour graphic screen with 7 touch-sensitive sections allows easy operation by using a menu structure to access the data. Thanks to the built-in web server, this can also be done remotely when a network connection is available.

The heart of the system is the EnCore with up to 16 GB of data memory. Diagnostic and self-checking functions in conjunction with a flexible, user-configurable data archive and an event list allow a detailed analysis of the meter’s performance and the metering situation at any time.

SonicExplorer®

Windows®-based software package for the Q.Sonic^{plus} for on-site and remote use. SonicExplorer is a tool that allows the health and performance of the device to be determined in situ so that informed decisions can be made in respect of maintenance or other tasks related to the ultrasonic flow meter.



Function overview:

- Meter data base
- Configuration, setting and documentation
- Diagnostics
- Health reporting
- Customer service pack (automated collection of relevant data for off-site analysis)

Flow Ranges Metric											
Type	Size		Flange Connection		Spool Diameter		Internal	Flow [m ³ /h]			Turndown
	[Inch]	DN	ANSI Schedule	EN1092-1	ANSI Flange Max ID [mm]	PN Flange Max ID [mm]	Diameter [mm]	Q _{min}	Q _t	Q _{max}	
	3	80	STD-XS XS-160	PN 10- PN 100	77.90 73.70	82.50	73 70	11 10	60 55	600 550	56 56
	4	100	STD-XS XS-120	PN 10- PN 100	102.30 97.20	107.10	97 90	13 11	100 90	1000 900	79 80
	6	150	STD-XS XS-120	PN 10- PN 100	154.10 146.30	159.30	146 139	18 16	220 200	2200 2000	124 125
	8	200	STD-XS XS-120	PN 10- PN 100	202.70 193.70	206.50	190 180	30 27	400 350	4000 3500	133 130
	10	250	STD-80 80-120	PN 10- PN 100	254.50 242.80	260.40	240 230	48 44	590 540	5900 5400	123 123
	12	300	30-60 60-100	PN 10- PN 100	307.00 295.30	309.70	295 280	73 66	860 780	8600 7800	118 118
	14	350	30-60 60-100	PN 10- PN 100	336.50 325.40	341.40	325 305	85 75	1000 900	10000 9000	118 120
	16	400	30-60 60-100	PN 10- PN 100	387.30 373.00	392.20	370 350	115 100	1300 1150	13000 11500	113 115
	18	450	STD 120	PN 10- PN 40		442.80	Max. 437.90 Min. 387.10	165 120	1800 1350	18000 13500	109 113
	20	500	STD 120	PN 10- PN 100		493.80	Max. 488.90 Min. 431.80	200 160	2100 1600	21000 16000	105 100
	24	600	STD 100	PN 10- PN 63		594.00	Max. 590.90 Min. 532.22	295 240	3000 2400	30000 24000	102 100
	26	650	STD S = 25.4	n/a			Max. 640.90 Min. 609.20	330 275	3300 2750	33000 27500	100 100
	30	750	STD S = 31.75	n/a			Max. 742.90 Min. 730.30	460 370	4600 3700	46000 37000	100 100
	36	900	STD S = 31.75	PN 10- PN 63		889.00	Max. 894.90 Min. 850.50	670 525	6700 5250	67000 52500	100 100
	42	1050	STD S = 31.75	n/a			Max. 1047.90 Min. 1003.50	920 750	8300 6750	83000 67500	90 90
	48	1200	STD S = 31.75	PN 10- PN 63		1194.00	Max. 1199.90 Min. 1155.50	1200 1000	11000 9100	110000 91000	92 91
	56	1400	S = 12.7 S = 31.75	PN 10- PN 40		1393.60	Max. 1396.60 Min. 1358.50	1650 1600	15000 14300	150000 143000	91 89

Flow Ranges Imperial

Type	Size		Flange Connection		Spool Diameter		Internal	Flow [MC FD]			Turndown
	[Inch]	DN	ANSI Schedule	EN1092-1	ANSI Flange Max ID [inch]	PN Flange Max ID [inch]	Diameter [inch]	Q _{min}	Q _t	Q _{max}	
	3	80	STD-XS	PN 10-	3.07	3.25	2.87	9	51	509	56
			XS-160	PN 100	2.90		2.76	8	47	466	56
	4	100	STD-XS	PN 10-	4.03	4.22	3.82	11	85	848	79
			XS-120	PN 100	3.83		3.54	9	76	763	80
	6	150	STD-XS	PN 10-	6.07	6.27	5.75	15	186	1865	124
			XS-120	PN 100	5.76		5.47	14	170	1695	125
	8	200	STD-XS	PN 10-	7.98	8.13	7.48	25	339	3390	133
			XS-120	PN 100	7.63		7.09	23	297	2966	130
10	250	STD-80	PN 10-	10.02	10.25	9.45	41	500	5001	123	
		80-120	PN 100	9.56		9.06	37	458	4577	123	
12	300	30-60	PN 10-	12.09	12.19	11.61	62	729	7289	118	
		60-100	PN 100	11.63		11.02	56	661	6611	118	
14	350	30-60	PN 10-	13.25	13.44	12.80	72	848	8476	118	
		60-100	PN 100	12.81		12.01	74	763	7628	120	
16	400	30-60	PN 10-	15.25	15.44	14.57	97	1102	11018	113	
		60-100	PN 100	14.69		13.78	85	975	9747	115	
18	450	STD 120	PN 10-		17.43	Max. 17.24	140	1526	15256	109	
			PN 40			Min. 15.24	102	1144	11442	113	
20	500	STD 120	PN 10-		19.44	Max. 19.25	170	1780	17799	105	
			PN 100			Min. 17	136	1356	13561	100	
24	600	STD 100	PN 10-		23.39	Max. 23.26	250	2543	25427	102	
			PN 63			Min. 20.95	203	2034	20341	100	
26	650	STD	n/a			Max. 25.23	280	2797	27969	100	
		S = 25.4		Min. 23.98		233	2331	23308	100		
30	750	STD	n/a			Max. 29.25	390	3899	38987	100	
		S = 31.75		Min. 28.75		314	3136	31359	100		
36	900	STD	PN 10-		35.00	Max. 35.23	568	5679	56786	100	
		S = 31.75	PN 63			Min. 33.48	445	4450	44496	100	
42	1050	STD	n/a			Max. 41.26	780	7035	70347	90	
		S = 31.75		Min. 39.51		636	5721	57210	90		
48	1200	STD	PN 10-		47.01	Max. 47.24	1017	9323	93231	92	
		S = 31.75	PN 63			Min. 45.49	848	7713	77127	91	
56	1400	S = 12.7	PN 10-		54.87	Max. 54.98	1398	12713	127133	91	
		S = 31.75	PN 40			Min. 53.48	1356	12120	121200	89	

For MID approved sizes and flow ranges, please also refer to the latest EC Type-examination Certificate T10335

Material Specifications ANSI 150-900 (flow cell)

LTCS Forging	ASTM A350-LF2 Cl.1
LTCS Welding	ASTM A333 Grade 6/ASTM A350-LF2 Cl.1
SS Forging	ASTM A182-F316
SS Welding	ASTM A312-TP316L/ASTM A182-F316L
LTCS/SS	Size > 24" as per Customer Specification
Material Certificate 3.1	

LTCS: Low Temperature Carbon Steel. Other Materials on Request.

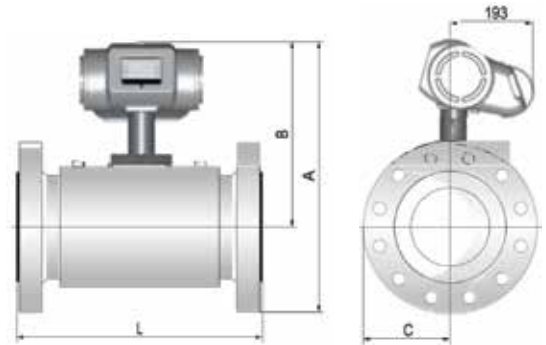

Flange Rating ANSI 150 Metric

Meter Size [inch]	Meter Size [mm]	Dimensions [mm]				Flow Cell Material	Weight Forged [kg]	Weight Welded [kg]	Length
		A	B	C	L				
3"	DN 80	517	422	147	320	LTCS/SS	47	-	4D
4"	DN 100	546	431	153	400	LTCS/SS	61	-	4D
6"	DN 150	570	430	184	450	LTCS/SS	84	-	3D
8"	DN 200	625	452	205	600	LTCS/SS	134	-	3D
10"	DN 250	680	477	252	750	LTCS/SS	195	-	3D
12"	DN 300	747	505	280	900	LTCS/SS	280	-	3D
14"	DN 350	802	535	310	1050	LTCS/SS	-	247	3D
16"	DN 400	859	561	336	1200	LTCS/SS	-	341	3D
18"	DN 450	903	586	331	1350	LTCS/SS	-	351	3D
20"	DN 500	961	611	356	1500	LTCS/SS	-	447	3D
24"	DN 600	1069	662	407	1800	LTCS/SS	-	687	3D
30"	DN 750	1230	738	492	2250	LTCS/SS	-	781	3D
32"	DN 800	1294	764	530	2400	LTCS/SS	-	929	3D
40"	DN 1000	1510	865	645	3000	LTCS/SS	-	1650	3D

Flange Rating ANSI 150 Imperial

Meter Size [inch]	Meter Size [mm]	Dimensions [inch]				Flow Cell Material	Weight Forged [lb]	Weight Welded [lb]	Length
		A	B	C	L				
3"	DN 80	20.3543	16.6142	5.7874	12.5984	LTCS/SS	102.63	-	4D
4"	DN 100	21.4961	16.9685	6.0236	15.7480	LTCS/SS	133.42	-	4D
6"	DN 150	22.4409	16.9291	7.2441	17.7165	LTCS/SS	184.55	-	3D
8"	DN 200	24.6063	17.7953	8.0709	23.6220	LTCS/SS	295.20	-	3D
10"	DN 250	26.7717	18.7795	9.9213	29.5276	LTCS/SS	430.12	-	3D
12"	DN 300	29.4094	19.8819	11.0236	35.4331	LTCS/SS	616.85	-	3D
14"	DN 350	31.5748	21.0630	12.2047	41.3386	LTCS/SS	-	544.41	3D
16"	DN 400	33.8189	22.0866	13.2283	47.2441	LTCS/SS	-	751.47	3D
18"	DN 450	35.5512	23.0709	13.0315	53.1496	LTCS/SS	-	774.79	3D
20"	DN 500	37.8346	24.0551	14.0157	59.0551	LTCS/SS	-	984.76	3D
24"	DN 600	42.0866	26.0630	16.0236	70.8661	LTCS/SS	-	1513.69	3D
30"	DN 750	48.4252	29.0551	19.3701	88.5827	LTCS/SS	-	1722.58	3D
32"	DN 800	50.9449	30.0787	20.8661	94.4882	LTCS/SS	-	2048.14	3D
36"	DN 900	55.0787	32.0472	22.9921	106.2992	LTCS/SS	-	2985.76	3D
40"	DN 1000	59.4488	34.0551	25.3937	118.1102	LTCS/SS	-	3638.29	3D

Flange Rating ANSI 300 Metric

Meter Size [inch]	Meter Size [mm]	Dimensions [mm]				Flow Cell Material	Weight Forged [kg]	Weight Welded [kg]	Length
		A	B	C	L				
3"	DN 80	527	422	147	320	LTCS/SS	51	-	4D
4"	DN 100	558	431	153	400	LTCS/SS	70	-	4D
6"	DN 150	589	430	184	450	LTCS/SS	101	-	3D
8"	DN 200	643	452	205	600	LTCS/SS	155	-	3D
10"	DN 250	700	477	252	750	LTCS/SS	226	-	3D
12"	DN 300	765	505	280	900	LTCS/SS	320	-	3D
14"	DN 350	827	535	310	1050	LTCS/SS	-	319	3D
16"	DN 400	884	561	336	1200	LTCS/SS	-	430	3D
18"	DN 450	941	586	356	1350	LTCS/SS	-	473	3D
20"	DN 500	999	611	388	1500	LTCS/SS	-	591	3D
24"	DN 600	1120	662	457	1800	LTCS/SS	-	911	3D
30"	DN 750	1284	738	546	2250	LTCS/SS	-	1252	3D
32"	DN 800	1339	764	575	2400	LTCS/SS	-	1575	3D
36"	DN 900	1449	814	635	2700	LTCS/SS	-	2159	3D
40"	DN 1000	1485	865	619	3000	LTCS/SS	-	2096	3D

Flange Rating ANSI 300 Imperial

Meter Size [inch]	Meter Size [mm]	Dimensions [inch]				Flow Cell Material	Weight Forged [lb]	Weight Welded [lb]	Length
		A	B	C	L				
3"	DN 80	20.7480	16.6142	5.7874	12.5984	LTCS/SS	112.06	-	4D
4"	DN 100	21.9685	16.9685	6.0236	15.7480	LTCS/SS	154.06	-	4D
6"	DN 150	23.1890	16.9291	7.2441	17.7165	LTCS/SS	221.76	-	3D
8"	DN 200	25.3150	17.7953	8.0709	23.6220	LTCS/SS	341.47	-	3D
10"	DN 250	27.5591	18.7795	9.9213	29.5276	LTCS/SS	499.02	-	3D
12"	DN 300	30.1181	19.8819	11.0236	35.4331	LTCS/SS	706.47	-	3D
14"	DN 350	32.5591	21.0630	12.2047	41.3386	LTCS/SS	-	702.53	3D
16"	DN 400	34.8031	22.0866	13.2283	47.2441	LTCS/SS	-	947.79	3D
18"	DN 450	37.0472	23.0709	14.0157	53.1496	LTCS/SS	-	1043.18	3D
20"	DN 500	39.3307	24.0551	15.2756	59.0551	LTCS/SS	-	1302.87	3D
24"	DN 600	44.0945	26.0630	17.9921	70.8661	LTCS/SS	-	2008.74	3D
30"	DN 750	50.5512	29.0551	21.4961	88.5827	LTCS/SS	-	2761.20	3D
32"	DN 800	52.7165	30.0787	22.6378	94.4882	LTCS/SS	-	3472.04	3D
36"	DN 900	57.0472	32.0472	25.0000	106.2992	LTCS/SS	-	4760.79	3D
40"	DN 1000	58.4646	34.0551	24.3701	118.1102	LTCS/SS	-	4621.40	3D

Flange Rating ANSI 600 Metric

Meter Size [inch]	Meter Size [mm]	Dimensions [mm]				Flow Cell Material	Weight Forged [kg]	Weight Welded [kg]	Length
		A	B	C	L				
3"	DN 80	527	422	147	320	LTCS/SS	53	-	4D
4"	DN 100	568	431	153	400	LTCS/SS	82	-	4D
6"	DN 150	608	430	185	500	LTCS/SS	134	-	3.33D
8"	DN 200	662	452	210	600	LTCS/SS	200	-	3D
10"	DN 250	731	477	254	750	LTCS/SS	312	-	3D
12"	DN 300	784	505	280	900	LTCS/SS	424	-	3D
14"	DN 350	837	535	310	1050	LTCS/SS	-	455	3D
16"	DN 400	903	561	343	1200	LTCS/SS	-	641	3D
18"	DN 450	957	586	372	1350	LTCS/SS	-	666	3D
20"	DN 500	1018	611	407	1500	LTCS/SS	-	853	3D
24"	DN 600	1132	662	470	1800	LTCS/SS	-	1311	3D
30"	DN 750	1304	738	565	2250	LTCS/SS	-	1932	3D
32"	DN 800	1361	764	597	2400	LTCS/SS	-	2266	3D
36"	DN 900	1472	814	657	2700	LTCS/SS	-	2956	3D
40"	DN 1000	1526	865	661	3000	LTCS/SS	-	3334	3D

Flange Rating ANSI 600 Imperial

Meter Size [inch]	Meter Size [mm]	Dimensions [inch]				Flow Cell Material	Weight Forged [lb]	Weight Welded [lb]	Length
		A	B	C	L				
3"	DN 80	20.7480	16.6142	5.7874	12.5984	LTCS/SS	116.93	-	4D
4"	DN 100	22.3622	16.9685	6.0236	15.7480	LTCS/SS	179.79	-	4D
6"	DN 150	23.9370	16.9291	7.2441	19.6850	LTCS/SS	295.42	-	3.33D
8"	DN 200	26.0630	17.7953	8.2677	23.6220	LTCS/SS	441.85	-	3D
10"	DN 250	28.7795	18.7795	10.0000	29.5276	LTCS/SS	688.08	-	3D
12"	DN 300	30.8661	19.8819	11.0236	35.4331	LTCS/SS	934.56	-	3D
14"	DN 350	32.9528	21.0630	12.2047	41.3386	LTCS/SS	-	1002.31	3D
16"	DN 400	35.5512	22.0866	13.5039	47.2441	LTCS/SS	-	1412.90	3D
18"	DN 450	37.6772	23.0709	14.6457	53.1496	LTCS/SS	-	1467.93	3D
20"	DN 500	40.0787	24.0551	16.0236	59.0551	LTCS/SS	-	1879.99	3D
24"	DN 600	44.5669	26.0630	18.5039	70.8661	LTCS/SS	-	2890.37	3D
30"	DN 750	51.3386	29.0551	22.2441	88.5827	LTCS/SS	-	4259.22	3D
32"	DN 800	53.5827	30.0787	23.5039	94.4882	LTCS/SS	-	4995.65	3D
36"	DN 900	57.9528	32.0472	25.8661	106.2992	LTCS/SS	-	6515.85	3D
40"	DN 1000	60.0787	34.0551	26.0236	118.1102	LTCS/SS	-	7349.42	3D

Flange Rating ANSI 900 Metric

Meter Size [inch]	Meter Size [mm]	Dimensions [mm]				Flow Cell Material	Weight Forged [kg]	Weight Welded [kg]	Length
		A	B	C	L				
3"	DN 80	542	422	147	320	LTCS/SS	62	-	4D
4"	DN 100	576	431	153	400	LTCS/SS	89	-	4D
6"	DN 150	620	430	190	600	LTCS/SS	167	-	4D
8"	DN 200	687	452	235	800	LTCS/SS	281	-	4D
10"	DN 250	750	477	273	750	LTCS/SS	360	-	3D
12"	DN 300	810	505	305	900	LTCS/SS	508	-	3D
14"	DN 350	856	535	321	1050	LTCS/SS	-	561	3D
16"	DN 400	913	561	323	1200	LTCS/SS	-	726	3D
18"	DN 450	980	586	394	1350	LTCS/SS	-	896	3D
20"	DN 500	1040	611	429	1500	LTCS/SS	-	1148	3D
24"	DN 600	1183	662	521	1800	LTCS/SS	-	1918	3D
30"	DN 750	1354	738	616	2250	LTCS/SS	-	2929	3D
32"	DN 800	1421	764	657	2400	LTCS/SS	-	3444	3D
36"	DN 900	1545	814	731	2700	LTCS/SS	-	4493	3D
40"	DN 1000	1621	865	756	3000	LTCS/SS	-	5135	3D

Flange Rating ANSI 900 Imperial

Meter Size [inch]	Meter Size [mm]	Dimensions [inch]				Flow Cell Material	Weight Forged [lb]	Weight Welded [lb]	Length
		A	B	C	L				
3"	DN 80	21.3386	16.6142	5.7874	12.5984	LTCS/SS	136.00	-	4D
4"	DN 100	22.6772	16.9685	6.0236	15.7480	LTCS/SS	196.83	-	4D
6"	DN 150	24.4094	16.9291	7.4803	23.6220	LTCS/SS	367.29	-	4D
8"	DN 200	27.0472	17.7953	9.2520	31.4961	LTCS/SS	619.68	-	4D
10"	DN 250	29.5276	18.7795	10.7480	29.5276	LTCS/SS	792.98	-	3D
12"	DN 300	31.8898	19.8819	12.0079	35.4331	LTCS/SS	1120.68	-	3D
14"	DN 350	33.7008	21.0630	12.6378	41.3386	LTCS/SS	-	1235.87	3D
16"	DN 400	35.9449	22.0866	12.7165	47.2441	LTCS/SS	-	1599.61	3D
18"	DN 450	38.5827	23.0709	15.5118	53.1496	LTCS/SS	-	1974.57	3D
20"	DN 500	40.9449	24.0551	16.8898	59.0551	LTCS/SS	-	2530.18	3D
24"	DN 600	46.5748	26.0630	20.5118	70.8661	LTCS/SS	-	4228.09	3D
30"	DN 750	53.3071	29.0551	24.2520	88.5827	LTCS/SS	-	6457.76	3D
32"	DN 800	55.9449	30.0787	25.8661	94.4882	LTCS/SS	-	7593.07	3D
36"	DN 900	60.8268	32.0472	28.7795	106.2992	LTCS/SS	-	9905.28	3D
40"	DN 1000	63.8189	34.0551	29.7638	118.1102	LTCS/SS	-	11320.72	3D

Q.Sonic^{plus} Technical Specifications

Technical Data	
Measurement Principle	Ultrasonic transit time measurement
Sizes	3" to 36" – larger sizes available upon request (DN 80 to DN 900)
Pressure range	2 bar (g) (29 psig) to 150 bar (g) (2175 psig); minimum pressure depending on size and gas composition
Process Temperature Ranges ⁴⁾	Standard: -40°C to +85°C (-40°F to +185°F) Extended: -50°C to +85°C (-58°F to +185°F) MID: -40°C to +85°C (-40°F to +185°F)
Ambient Temperature Range ⁴⁾	Standard: -40°C to +70°C (-40°F to +158°F) Extended: -50°C to +70°C (-58°F to +158°F) MID: -40°C to +55°C (-40°F to +131°F)
Repeatability	0.05% ¹⁾
Typical Uncertainty	0.5% of reading after dry calibration ²⁾ 0.2% of reading after flow calibration ²⁾ 0.1% of reading after flow calibration and linearization ²⁾
Body Materials	Low-temperature carbon steel ≤ 12": ASTM A350-LF2 Cl.1 ≥ 14": ASTM A333 grade 6/ASTM A350-LF2 Cl.1 Stainless steel ≤ 12": ASTM A182-F316 ≥ 14": ASTM A312-TP316L/ASTM A182-F316L Other materials on request
Material Certificate	EN 10204 3.1 (3.2 on request)
Body Construction Details	≤ 16": reduced bore, tapering angle 7° ≥ 18": full bore
Pressure Reference Points	½" NPT (G½ on request)
Electronic Enclosure Material	Cast aluminium alloy. Optional stainless steel.
Power Supply	Nominal 24 V DC (18-30 V DC), 10-20 W (depending on installed optional cards)
Local Display	GUI, 4.3" (10.9 cm) widescreen graphical colour display with 7 capacitive soft keys (touch), LEDs for power and status
Interfaces	- 2 serial ports (RS 232/485 configurable) - 1 Ethernet port/high-speed VDSL (VDSL option replaces Ethernet port) - 2 frequency outputs, 0 to 3 kHz - 2 digital outputs ³⁾ - 2 analogue outputs ³⁾ - 1 USB port (device, for service purpose only)
Communications Protocol	- Modbus (ASCII, RTU, TCP/IP) - UNIFORM - UNIFORM Series IV 4-path compatibility mode - MMS (Manufacturing Message Specification) - Built-in web server
Metrological Approval	MID T10335 (optional)
MID Accuracy	Class 1.0
Hazardous Area Approvals	ATEX: Ex d ia [ia] IIB+H2 T6 Gb IECEX: Ex d ia [ia] IIB+H2 T6 Gb FM: Class I, Division 1, Group A to D T6 CSA: Class I, Division 1, Groups B, C and D T6; Ex d ia [ia] IIB+H2 T6
Ingress Protection	IP 66/NEMA Type 4X

¹⁾ Q_i to Q_{max}

²⁾ Q_i to Q_{max}, with straight inlet/outlet spool of 10D/3D

³⁾ Analogue outputs and digital outputs sharing the terminal clamps

⁴⁾ Ranges: subject to application and (hazardous area) approval

For more information

To learn more about Honeywell's Integrated Gas Solutions, visit www.honeywellprocess.com or contact your Honeywell account manager.

Honeywell Process Solutions

Honeywell House, Arlington Business Park
Bracknell, Berkshire, England RG12 1EB

1250 West Sam Houston Parkway South
Houston, TX 77042 USA Tel: +1 832 252 3000

33F, Tower A, Shanghai City Centre 100 Zunyi
Road, Shanghai, China 200051
www.honeywellprocess.com

Germany Elster GmbH Steinern Straße 19-21
55252 Mainz-Kastel
www.elster.com

Elster® and SonicExplorer® are registered
trademark of Honeywell International, Inc.
*All other trademarks are the property of their
respective owners.

BR-16-39-ENG | 09/16
©2016 Honeywell International Inc.

Honeywell