

Honeywell

MAXON

KINEMAX[®]

MEDIUM VELOCITY GAS OR OIL BURNERS

TECHNICAL CATALOG



PRODUCT DESCRIPTION

The KINEMAX[®] burner is a nozzle-mixing, medium velocity burner. It provides a stream of hot combustion gases that promote circulation within your furnace, improving both temperature uniformity and workload penetration.

The air/fuel mixing design allows for the burner to be operated on ratio throughout the firing range, with excess air up to 4700% for some sizes or with excess fuel.

Series G KINEMAX[®] Burners are designed to operate on natural gas, propane or butane but can burn other gaseous fuels as well.

Combustion air enters the burner body and is swirled out into the burner block through the internal air orifice plate. Low pressure gas enters the burner body and exits to the block through machined ports in the gas nozzle.

The gas and air are intimately mixed in the cast burner block tunnel. The spark ignitor is positioned to intersect the fuel/air mixture directly in front of the nozzle face.

Pilot gas is introduced directly behind the gas ports in the gas nozzle and essentially flows through to the burner block through the same ports as does the main gas. The pilot capacity is the minimum firing rate of the KINEMAX[®] burner.



32M-02004-01

FEATURES

- Exit velocities up to 300 km/h (85 m/s) to promote workload heat penetration and better furnace temperature uniformity
- Operate on-ratio, with excess fuel or with excess air to meet the specific demands of your combustion process needs
- Burns most clean, low pressure gaseous fuels or light oil
- Turndown capability up to 48:1

- Maximum application flexibility with 7 different sizes and maximum capacities ranging from 110 kW up to 2460 kW
- Lower fuel consumption using preheated combustion air (up to 425 °C)
- Refractory block for chamber temperatures up to 1650 °C
- Removable backplate, providing access for easy inspection and/or maintenance
- KINEMAX[®] burners can be used with oxygen enriched combustion air

- 1) Burner body
- 2) Burner block
- 3) Air orifice plate
- 4) Gas nozzle
- 5) Spark ignitor
- 6) Main gas inlet
- 7) Combustion air inlet
- 8) UV scanner connection
- 9) Pilot gas connection

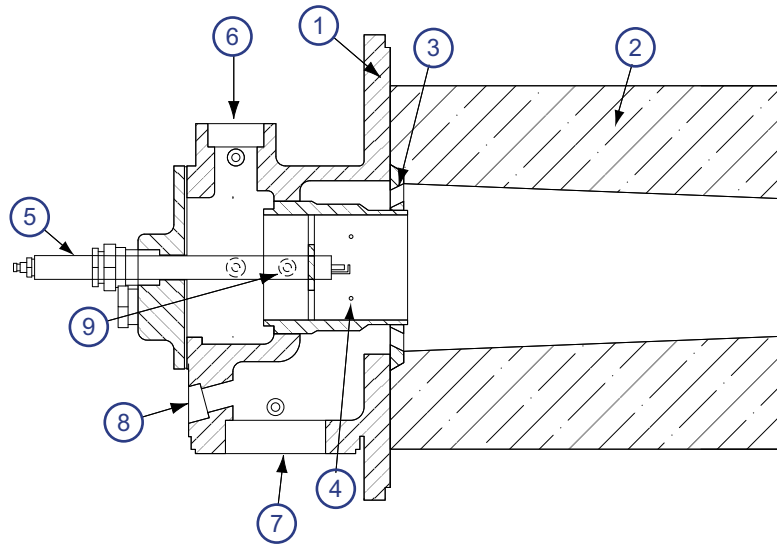

Series C KINEMAX[®] Burners are designed to operate on gas or on light oil.

Combustion air enters the burner body and is swirled out into the burner block through the air orifice plate. Low pressure gas enters the body and exits to the block through the gas tube and nozzle.

For light oil firing, the n° 2 oil enters through the strainer and oil tube going to the oil spinner nozzle where the stream of liquid oil is atomized by the atomizing air directly in front of the spark ignitor.

Gas for the pilot comes in through a separate inlet in the gas body and flows down the gas tube where it spins out the face of the gas nozzle in front of the spark ignitor.

- 1) Burner body
- 2) Burner block
- 3) Air orifice plate
- 4) Gas tube and nozzle
- 5) Spark ignitor
- 6) Main gas inlet
- 7) Combustion air inlet
- 8) Atomizing air inlet
- 9) Oil inlet
- 10) Combustion air pressure connection
- 11) Pilot gas inlet
- 12) Alternate Scanner Port
- 13) Atomizing air tube

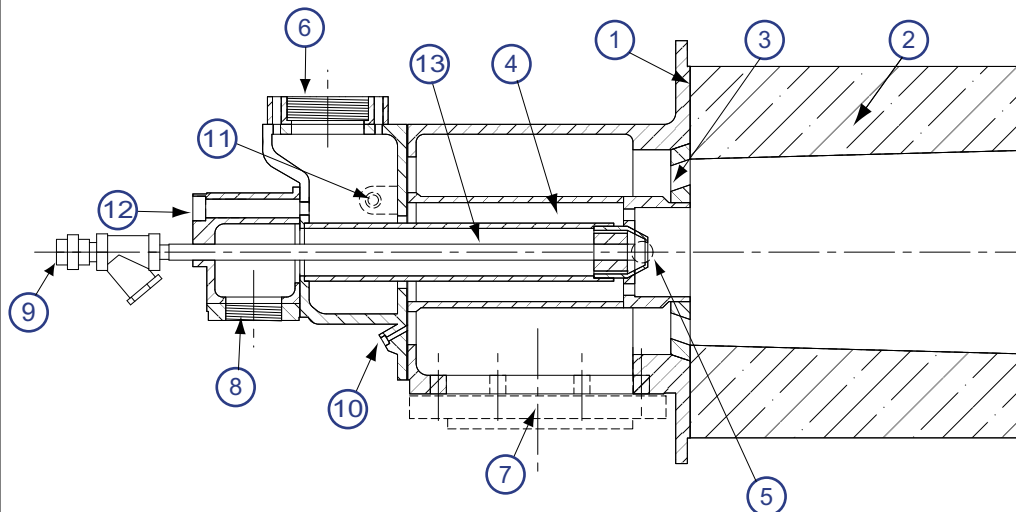

Available KINEMAX[®] sizes

Typical burner data										
Fuel: natural gas with 10.9 kWh/Nm³ HHV - sg = 0.6 [1]										
Combustion air: 15 °C - 21% O₂ - 50% Humidity - sg = 1.0 [1]										
Stated pressures are indicative. Actual pressures are a function of air humidity, altitude, type of fuel and gas quality.										
KINEMAX [®] size	Series G (gas only)					Series C (gas/oil) [2]				
	1.5-G	2-G	3-G	4-G	6-G	2-C (gas)	2-C (oil)	6-C (gas)	6-C (oil)	
Max. capacity kW HHV	161	294	704	1174	2348	290	290	2460	2460	
Turndown ratio (with 75% excess air)	27:1	50:1	96:1	133:1	40:1	28:1	28:1	16:1	16:1	
Comb. air flow at max. capacity Nm ³ /h	150	272	655	1091	2182	285	285	2500	2500	
Natural gas inlet pressure mbar	10	10	9	8	15	10	10	15	15	
Comb. air pressure at inlet mbar	65	65	65	65	65	65	65	65	65	
Pilot capacity /min. capacity kW HHV	6	6	7	9	60	12	12	150	150	
Oil inlet pressure bar	-	-	-	-	-	-	0.7	-	0.9	

[1] sg (specific gravity) = relative density to air (density air = 1.293 kg/Nm³).

[2] light oil (#2 oil): 12.5 kWh/kg - viscosity to be max 7cSt (7.10⁻⁶ m³/s)

APPLICATIONS

KINEMAX[®] burners are designed to be used in high temperature furnaces. They are commonly applied on heat treatment furnaces, oxidizers, melting furnaces, ceramic furnaces and other high temperature applications.

- 1) KINEMAX® burner
- 2) MAXON fuel safety shut-off valves
- 3) Control panel
- 4) Combustion air blower
- 5) MAXON MICRO-RATIO® or SMARTLINK® fuel/air ratio control valve

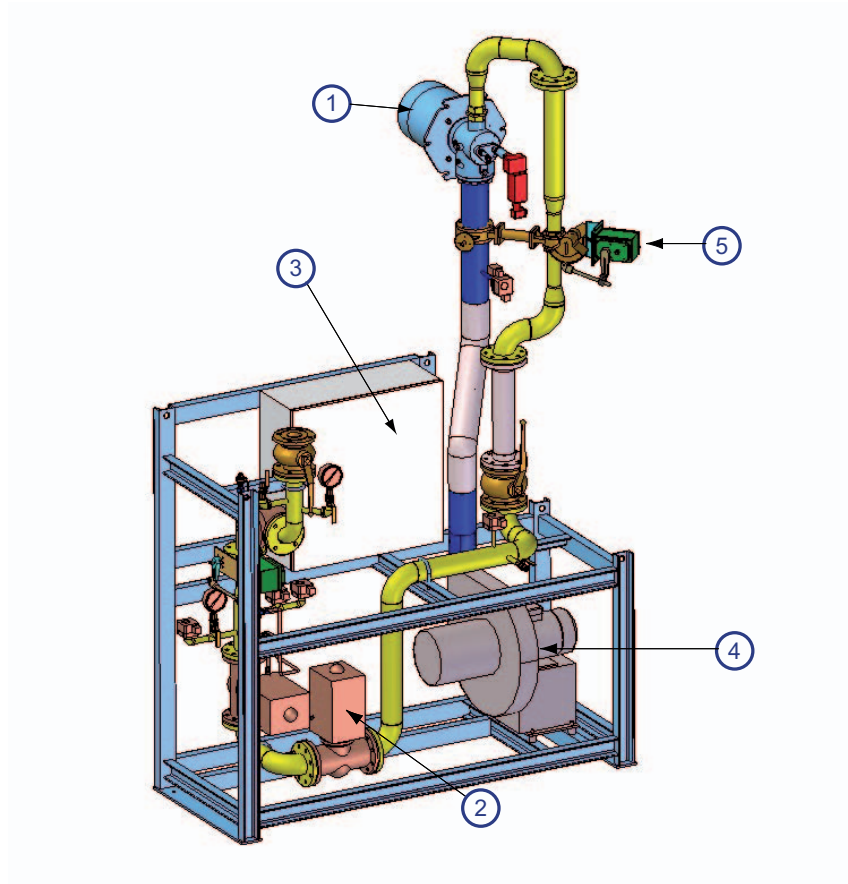

KINEMAX® Size 4 gas only burner in a complete system with burner control panel and natural gas pipe-train, including MAXON fuel safety shut-off valves and MAXON gas/air ratio control valve.

DIMENSIONS AND WEIGHTS

KINEMAX® Series G - sizes 1.5 - 2 - 3 - 4

Gas only

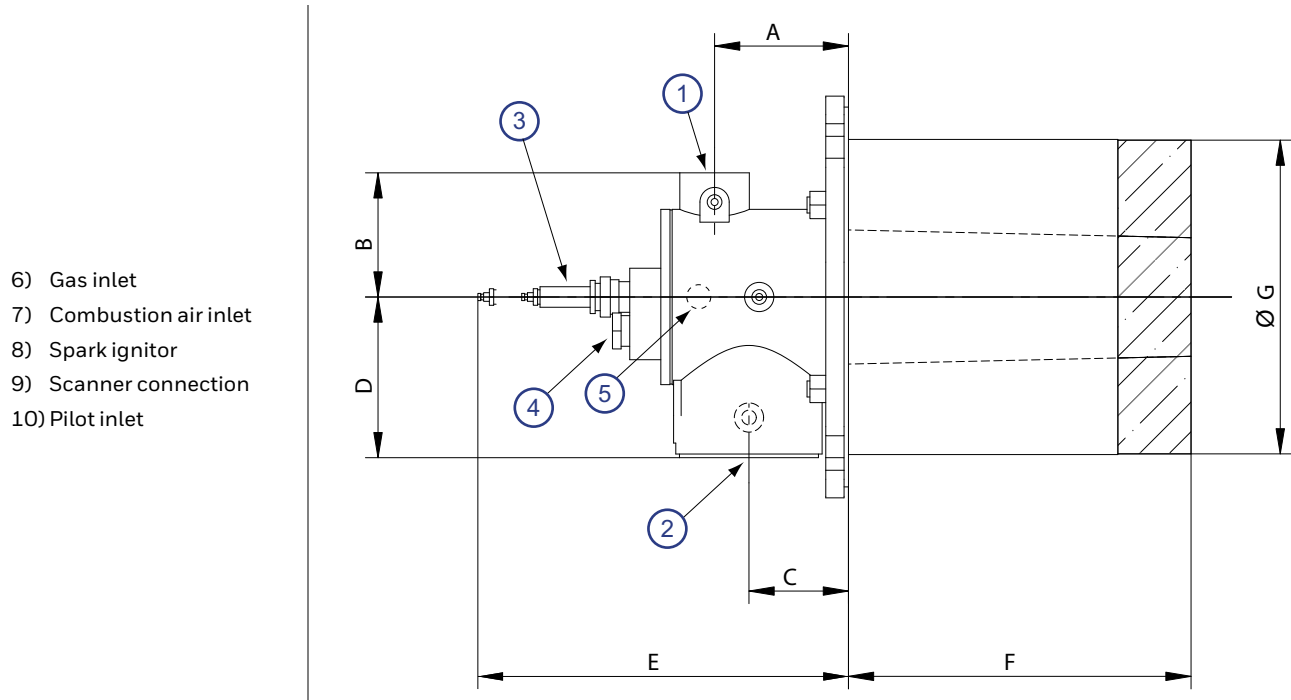

- 6) Gas inlet
- 7) Combustion air inlet
- 8) Spark ignitor
- 9) Scanner connection
- 10) Pilot inlet

Dimensions in mm unless stated otherwise															
Burner size	Gas inlet [1]		Comb.air inlet [1]		A	B	C	D	E [2]	F			ØG		Weight (kg) [3]
	ANSI	ISO	ANSI	ISO						std. block	long block (opt.)	sleeve (opt.)	block	sleeve (opt.)	
1.5	3/4" NPT	Rp 3/4"	1 1/2" NPT	Rp 1 1/2"	94	86	70	110	280	235	343	240	219	102	34
2	1" NPT	Rp 1"	2" NPT	Rp 2"	94	86	70	110	280	235	343	240	219	108	34
3	1 1/2" NPT	Rp 1 1/2"	3" NPT	Rp 3"	113	106	84	162	365	235	343	240	257	137	42
4	2" NPT	Rp 2"	4" NPT	Rp 4"	122	114	103	178	407	235	343	240	279	174	50

[1] Gas and air inlet are standard threaded connections. Optional welding flanges are available for sizes 3" and up.

[2] Includes clearance for spark ignitor removal.

[3] Weights are for burner with standard block. Data for burners with long block or stainless steel sleeve might differ slightly.

KINEMAX[®] Series G - size 6

Gas only

- 1) Gas inlet
- 2) Combustion air inlet
- 3) Spark ignitor
- 4) Scanner connection
- 5) Pilot inlet

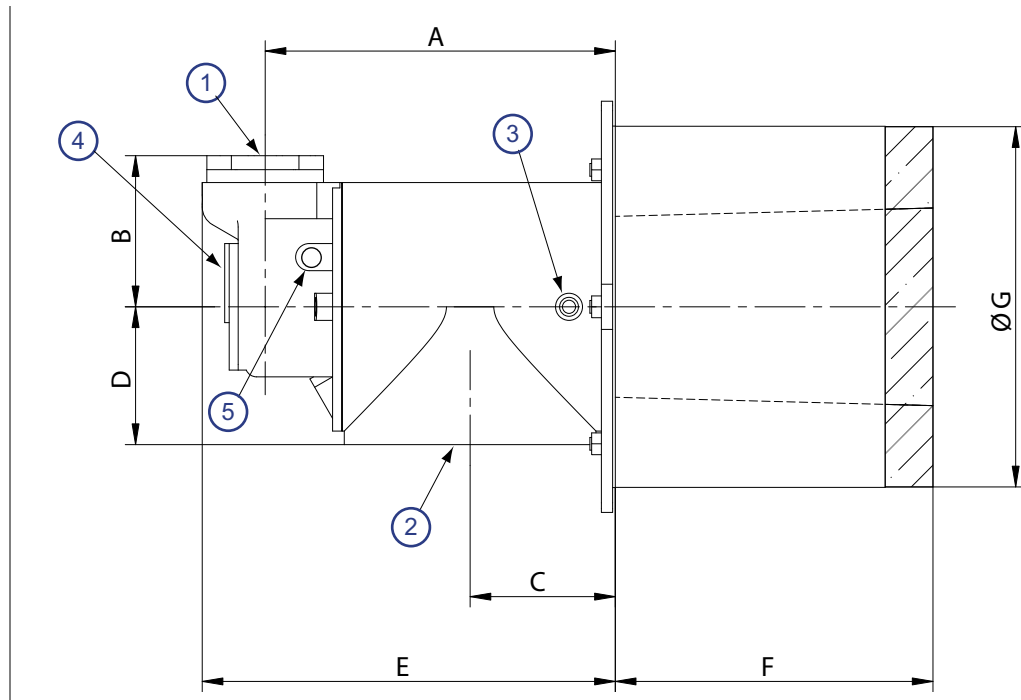

Dimensions in mm unless stated otherwise

Gas inlet [1]		Comb.air inlet [1]		A	B	C	D	E	F		ØG		Weight (kg) [2]
ANSI	ISO	ANSI	ISO						std. block	sleeve (opt.)	block	sleeve (opt.)	
3" NPT	Rp 3"	6" NPT	Rp 6"	394	167	160	197	463	362	318	407	213	125

[1] Gas and air inlet are available with threaded connections or with welding flanges (not included).

[2] Weight is for burner with standard block. Burner with long block or stainless steel sleeve might differ slightly.

KINEMAX[®] Series C - size 2

Gas/oil burner

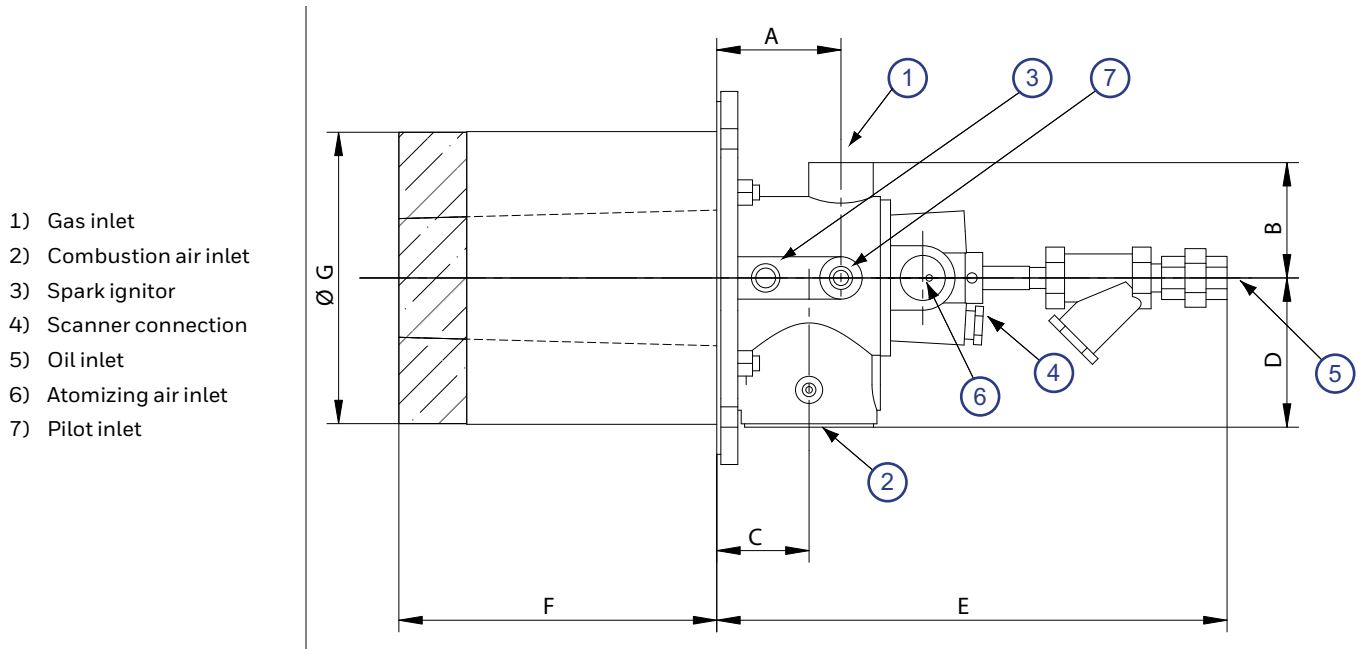

Dimensions in mm unless stated otherwise																
Gas inlet		Comb.air inlet		Atom. Air inlet		Oil inlet		A	B	C	D	E [1]	F		ØG	Weight (kg) [2]
ANSI	ISO	ANSI	ISO	ANSI	ISO	ANSI	ISO						std block	long block		
1" NPT	Rp 1"	2" NP T	Rp 2"	1" NP T	Rp 1"	1/4" NPT	Rp 1/4"	94	86	70	110	348	235	343	219	40

[1] Add 170 mm for clearance of oil gun.

[2] Weight is for burner with standard block. Burner with long block might differ slightly.

KINEMAX® Series C - size 6

Gas/oil burner

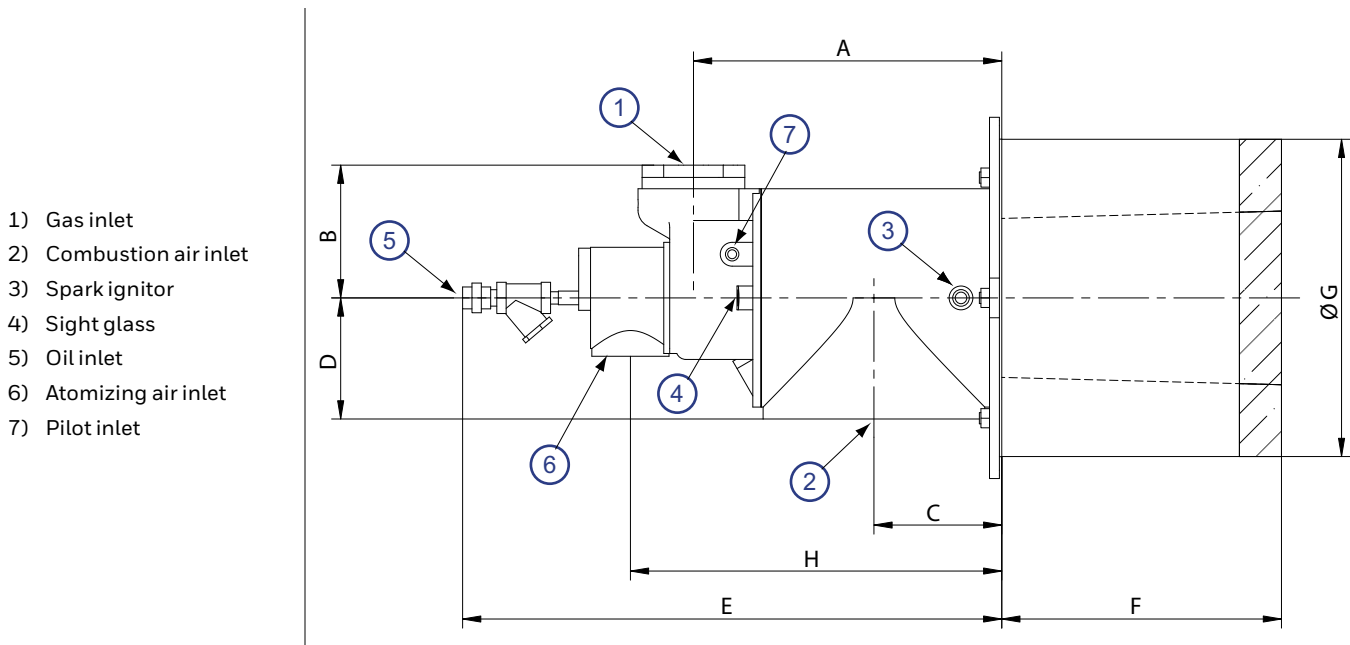

Dimensions in mm unless stated otherwise																		
Gas inlet [1]		Comb.air inlet [1]		Atom. Air inlet		Oil inlet		A	B	C	D	E [2]	F		ØG		H	Weight (kg) [3]
ANSI	ISO	ANSI	ISO	ANSI	ISO	ANSI	ISO						std. block	sleeve	block	sleeve		
3" NP T	Rp 3"	6" NP T	Rp 6"	2" NP T	Rp 2"	3/8" NPT	Rp 3/8"	394	197	160	197	692	362	318	407	213	478	140

[1] Gas and air inlet are available with threaded connections or with welding flanges (not included).

[2] Add 500 mm for clearance of oil gun.

[3] Weight is for burner with standard block. Burner with sleeve might differ slightly.

Read "Specifications of KINEMAX® burners" on page 9" for more detailed information on KINEMAX® burners.

SPECIFICATIONS OF KINEMAX[®] BURNERS

Series G KINEMAX[®] burners

Gas only

Typical burner data																
Fuel : natural gas at 15 °C with 10.9 kWh/Nm ³ HHV - sg = 0.6 [1]																
Combustion air : 15 °C - 21 % O ₂ - 50 % humidity - sg = 1.0 [1]																
Stated pressures are indicative - actual pressures are function of air humidity, altitude, type of fuel, gas quality.																
Performance factors	Burner size			1.5 Series G			2 Series G			3 Series G			4 Series G			6 Series G
	Combustion air diff. pressure	[2]	mbar	30	50	65	30	50	65	30	50	65	30	50	65	65
Combustion air volume for max. capacity (no excess air)		m ³ _(st) /h		102	132	150	191	246	272	436	560	655	736	951	1091	2182
Capacities	Maximum	kW (HHV)		110	142	161	205	265	294	470	602	704	793	1024	1174	2348
	Maximum with 425 °C preheated combustion air	kW (HHV)		72	92	104	133	172	190	305	393	457	513	665	762	1524
	On-ratio pilot / min.	kW (HHV)		9			9			12			15			88
	Pilot/minimum with 75% excess air	kW (HHV)		6			6			7			9			59
	Turndown ratio with 75% excess air			27.5:1			50:1			96:1			133:1			40:1
Performance limits with full excess air	Percent excess air	%		180	220	260	270	340	390	310	390	470	260	330	390	3900
	Turndown ratio with full excess air			11:1	13:1	16:1	20:1	25:1	29:1	32:1	40:1	48:1	27:1	34:1	40:1	16:1
	Minimum capacity to light burner	kW (HHV)		10			10			15			29			147
Differential gas pressure required for max capacity		[2] mbar		5	8	10	5	8	10	4	7	9	4	6	8	15
Flame Geometry	Length	[4] mm		100	150	200	200	250	360	300	460	610	610	760	1000	1200
	Diameter	mm		100	130	150	100	130	150	200	250	300	250	300	380	910

[1] sg (specific gravity) = relative density to air (density air = 1.293 kg / Nm³).

[2] Combustion air and gas differential pressure are measured between burner test connections and combustion chamber pressure.

[3] Pilot gas must be regulated separately to 7.5 mbar - 10 mbar at pilot inlet. For light off with full excess air, pilot must be increased to the indicated main burner minimum capacity, requiring considerably higher gas pressures.

[4] Flame lengths measured from the end of the burner block at maximum rated capacity. Overfiring or excess fuel operation requires higher natural gas supply pressures and gives longer flame lengths.

Series C KINEMAX[®] burners

Gas/oil

Typical burner data				
Fuel : natural gas at 15 °C with 10.9 kWh/Nm ³ HHV - sg = 0.6 [1]				
Fuel : light oil (#2): 12.5 kWh/kg - viscosity to be max. 7cSt (7.10-6 m ² /s)				
Combustion air : 15 °C - 21% O ₂ - 50 % humidity - sg = 1.0 [1]				
Stated pressures are indicative - actual pressures are function of air humidity, altitude, type of fuel, gas quality				
Performance factors	Burner Size		2 Series C	6 Series C
	Combustion air diff. Pressure [2]	mbar	65	65
Capacities	Maximum	kW (HHV)	293	2462
		kg/h oil	23	193
	On-ratio pilot/minimum with interrupted pilot	kW (HHV)	18	227
		kg/h oil	1.45	17.7
	Pilot/minimum with 75% excess air [5]	kW (HHV)	12	154
kg/h oil		0.97	12	
	Turndown ratio with 75% excess air		28.6:1	16:1
Performance limits with full excess air _[3]	Percent excess air	%	535	1100
	Turndown ratio with full excess air		5.3:1	10:1
	Minimum capacity to light burner	kW (HHV)		62
kg/h oil			5	19
Air volume for maximum capacity (no excess air)	Combustion air @ 65 mbar	m(st) ³ /h	284	2500
	Atomizing air @ 65 mbar [4]	m(st) ³ /h	34	119
	Differential gas pressure required for max capacity [2]	mbar	10	15
	Differential fuel supply pressure (N ^o 2 oil) for max. capacity	bar	0.69	0.9
Flame Geometry	Length [6]	mm	900	2450
	Diameter	mm	200	600

[1] sg (specific gravity) = relative density to air (density air = 1.293 kg/Nm³).

[2] Combustion air and gas differential pressure are measured between burner test connections and combustion chamber pressure.

[3] Excess air based on min. capacity required for ignition. Increased smoke numbers possible, depending on air temperature and fuel-oil quality.

[4] When gas firing on series C burners, a ½" diameter by-pass line is necessary to keep atomizing air passage purged. When oil firing, the use of a flame rod for flame detection is not possible. Atomizing air should be fresh and not pre-heated, indicated air pressures and flows should always be available over the entire capacity range.

[5] Pilot gas must be regulated separately to 7.5 mbar-10 mbar at pilot inlet. For light off with full excess air however, pilot must be increased to the indicated main burner minimum capacity, requiring considerably higher gas pressures.

[6] Flame lengths measured from the end of the burner block at maximum rated capacity. Overfiring or excess fuel operation requires higher natural gas supply pressures and gives longer flame lengths.

materials of construction	
housing	gray iron
gas nozzle	carbon steel
air orifice plate	carbon steel
block sleeve	carbon steel
	AISI 304 (1.4301)
block	castable refractory
sleeve (without block)	AISI 310 (1.4541)

SELECTION CRITERIA

KINEMAX[®] burner versions

The KINEMAX[®] burner is available in two basic versions. KINEMAX[®] type G burners are designed to operate on gas only. KINEMAX[®] type C burners are able to operate on both gas and light oil (not simultaneously). Each type has different sizes available to cover a broad range of capacities to suit all heating applications.

All burners are available in ANSI and ISO version. Connections larger than 2" are available as threaded or flanged. (see detailed drawings on page O-0-13)

Burner discharge sleeves are available in different lengths and materials:

- **standard version** with refractory block for installation in refractory walls, available in different lengths.
- **complete with block sleeve** to provide additional block support in chamber walls of softwall constructions. Block sleeves are available in stainless or carbon steel.
- **complete with stainless steel discharge sleeve** offering lightweight refractory-less burner for use in air heating applications. Maximum upstream temperature is 538° C and maximum downstream temperature for this configuration is 816° C
- Optional mounting flange enables easy mounting in cases where the standard or extended block lengths do not comply with installation insulation thickness.

KINEMAX [®] size		Standard version (block/ no sleeve)		Block with carbon steel sleeve		Block with stainless steel sleeve		Stainless steel sleeve (no block)
		standard	extended	standard	extended	standard	extended	
GAS ONLY	G-1.5	x	x	x o		x o	x o	x
	G-2	x	x	x o		x o	x o	x
	G-3	x	x	x o		x o	x o	x
	G-4	x	x	x o		x o	x o	x
	G-6	x				x		x
GAS / OIL	C-2	x	x	x o		x o	x o	x
	C6	x				x		x

x : discharge sleeve availability
o : optional mounting flange available

Application details

In high temperature furnaces KINEMAX[®] burners can be used wherever good temperature uniformity without flame impingement is required. Among the typical applications are oxidizers, forge furnaces, annealing furnaces, melting furnaces, lehrs, kilns, ceramic furnaces, etc. They can also be used in certain air heating applications. Special considerations have to be taken to protect the flame from high cross velocities. Contact MAXON for more details.

Maximum capacities

All KINEMAX[®] burners can be fired on-ratio, excess gas (40%) or with excess air (depending on size, up to 4700%). Performance data are given on page O-0-9.

Maximum capacity is a function of differential air pressure supplied to the burner air inlet as read between air test connection and combustion chamber. Combustion air blower rating must be sized to allow for manifold pressure losses.

Preheated air

Preheated combustion air up to 425° C can be accommodated by standard KINEMAX[®] burner, resulting in lower fuel consumptions.

The preheated combustion air can have reduced oxygen levels (as low as 17% O₂ if combustion air is 797 °F). Mixing of some low O₂ flue gas allows to combine system thermal efficiency with best emissions.

Process temperature

Standard refractory block permits operation at combustion chamber temperatures of 1425 °C. Special refractory block material allows operation up to 1650 °C.

The optional stainless steel sleeve (without block) can only be used when secondary cooling air (t° < 300 °C) is available and can be forced over the combustion sleeve.

Piloting and ignition

KINEMAX[®] burners are equipped with an integrated raw gas pilot, but can use direct ignition as well. Recommended 3/8" pilot gas fine adjustment needle valve is available as an option. Pilots shall be used only for ignition of the main flame (interrupted pilot). Permanent pilot operation is not advised (no permanent or intermittent pilot). Use the main burner at minimum capacity for continuous operation.

Use minimally 5000 V/200 VA ignition transformers for sparking of the spark ignitor.

Locate pilot gas valves as close as possible to the pilot burner gas inlet, to have fast ignition of the pilot burner.

Typical ignition sequences

- Pre purge of burner and installation, according to the applicable codes and the installation's requirements.

- Combustion air control valve shall be in the minimum position to allow minimum combustion air flow to the burner.
- In case of oil firing: atomizing air should be applied to the burner.
- Pre-ignition (typically 2s sparking in air).
- Open pilot gas and continue to spark the ignitor (typically 5s).
- Stop sparking, continue to power the pilot gas valves and start flame check.
Trip burner if no flame can be detected from here on.
- Check pilot flame stability (typical 5s to prove the stable pilot).
- Open main gas or oil valves and allow enough time to have main gas or oil in the burner. (typical 5s + time required to have main gas or oil in the burner).
- Close the pilot gas valves.
- Release to modulation (allow modulation of the burner).

Above sequences shall be completed to include all required safety checks during the start-up of the burner (process & burner safeties).

Ratio control

KINEMAX[®] burners can be fired on ratio throughout the firing range or set to give a choice between on ratio and excess air or excess fuel firing. As high as 4700% excess air is possible at minimum capacity. Air / fuel ratio control can be accomplished with MAXON MICRO-RATIO[®] valves and SMARTLINK[®] technology.

Flame supervision

All KINEMAX[®] burner sizes and types can be supervised by means of a UV-scanner.

Burner design incorporates UV-scanner port suitable for supervision of both pilot and main flames.

Two scanner positions are available (see drawings on page 0-0-13)

Pay attention to possible pick-up of strange flames (if any in the furnace) when using UV-scanner for flame detection. Allow some purge or cooling air to the scanner connections (typically 70 ft³(st)/h of fresh clean air)

Scanners should be installed as close to the burner as possible.

Sizes 1-1/2 up to 4 have a flame rod assembly option available. Flame rod sensing should not be used on oil firing.

Flame development

KINEMAX[®] burners shall be installed in combustion chambers or furnaces that allow full development of the burner flame. Cylindrical combustion chambers or flame protection sleeves shall be sized correctly.

Consult MAXON for proper combustion chamber lay-out.

Combustion air and gas piping

Combustion air piping to the burner shall be done in such way that the air flow to the burner will not disturb the flame. For optimum performance, the first elbow in combustion air piping must be at least six pipe diameters from burner test connection. Location of air control valves directly on the burner inlet is not advised. When possible, locate the air/gas/oil control valves in a position that allows viewing of burner flame during adjustment. Protect control valve operator from excessive radiant and/or ambient heat.

When using one air/gas control valve for multiple KINEMAX[®] G burners, gas check valves should be installed as close as possible to each burner inlet for dependable light off. MAXON air and gas balancing valves may be used on multi-burner installations for improving heating uniformity.

Oxygen enriched combustion air

MAXON KINEMAX[®] burners can be used with oxygen enriched combustion air.

Consult MAXON for more information.

DIMENSIONS

KINEMAX® Size 1.5 and 2 – type G

Gas only

- 1) Gas inlet
- 2) Combustion air inlet
- 3) Gas pressure test connection
- 4) Combustion air pressure test connection
- 5) Flame supervision port
1/2" (NPT or ISO)
- 6) Alternate scanner connection
1/2" (NPT or ISO)
- 7) Sight glass
- 8) Spark ignitor
- 9) Pilot gas inlet
3/8" (NPT or ISO)
- 10) Optional block sleeve
(carbon steel or stainless steel)
- 11) Optional mounting flange (only in combination with block sleeve)

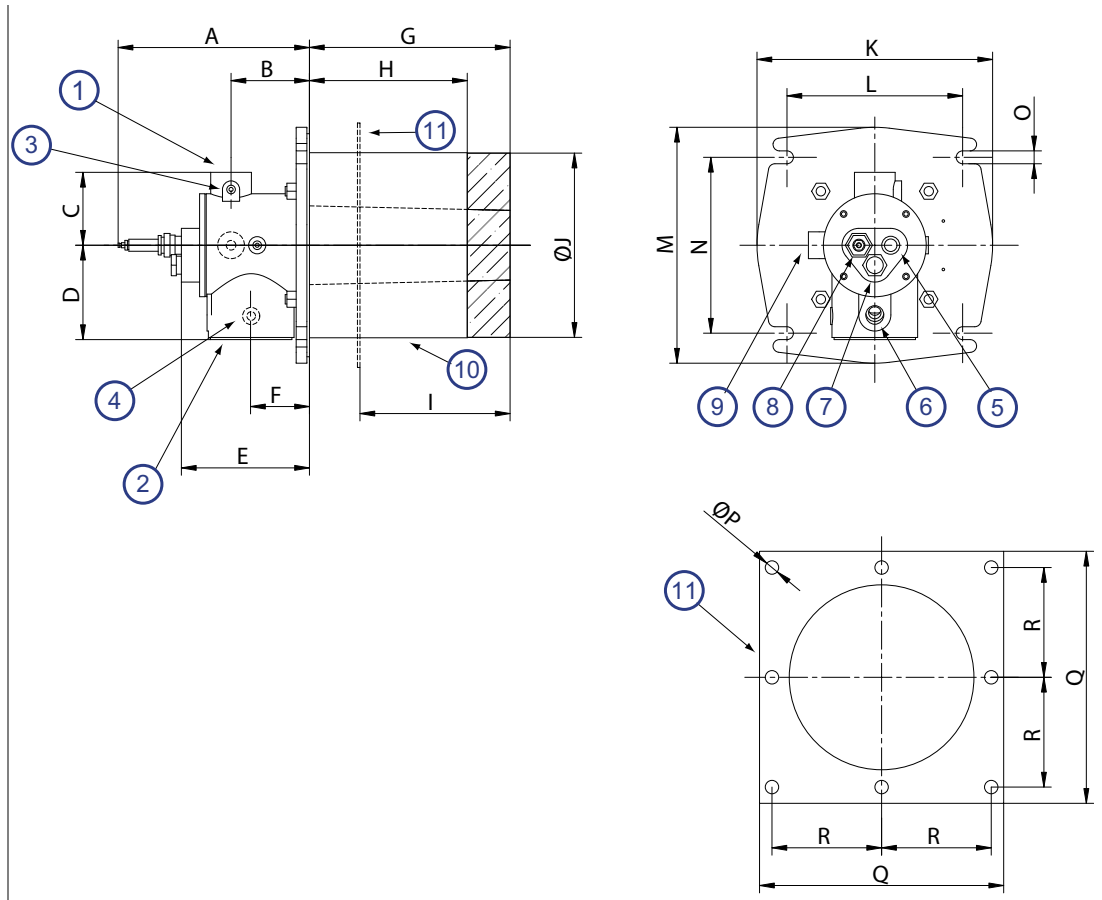

Dimensions in mm unless stated otherwise																		
Burner size	Gas inlet		Air inlet		A [1]	B	C	D	E	F	K	L	M	N	O	P Ø	Q	R
	ANSI (NPT)	ISO (Rp)	ANSI (NPT)	ISO (Rp)														
1.5"	3/4	3/4	1.1/2	1.1/2	280	94	86	109.5	154	70	280	208	280	209	15	16	299	130
2"	1	1	2	2	280	94	86	109.5	154	70	280	208	280	209	15	16	299	130

[1] includes clearance for removal.

Dimensions in mm unless stated otherwise

Burner size	Carbon steel block sleeve					Stainless steel block sleeve					Stainless steel long block sleeve					Stainless steel sleeve (no block)	
	Standard block					Standard block					Extended block					G	JØ
	G	H	I min	I max	J Ø	G	H	I min	I max	J Ø	G	H	I min	I max	J		
1.5"	235	57	50	184	219	235	184	50	184	219	343	254	90	292	219	241	102
2"	235	57	50	184	219	235	184	50	184	219	343	254	90	292	219	241	108

KINEMAX[®] Size 3 and 4 – type G

Gas only

- 1) Gas inlet
- 2) Combustion air inlet
- 3) Gas pressure test connection
- 4) Combustion air pressure test connection
- 5) Flame supervision port
1/2" (NPT or ISO)
- 6) Alternate scanner connection
1/2" (NPT or ISO)
- 7) Sight glass
- 8) Spark ignitor
- 9) Pilot gas inlet
3/8" (NPT or ISO)
- 10) Optional block sleeve
(carbon steel or stainless steel)
- 11) Optional mounting flange
(only in combination with block sleeve)

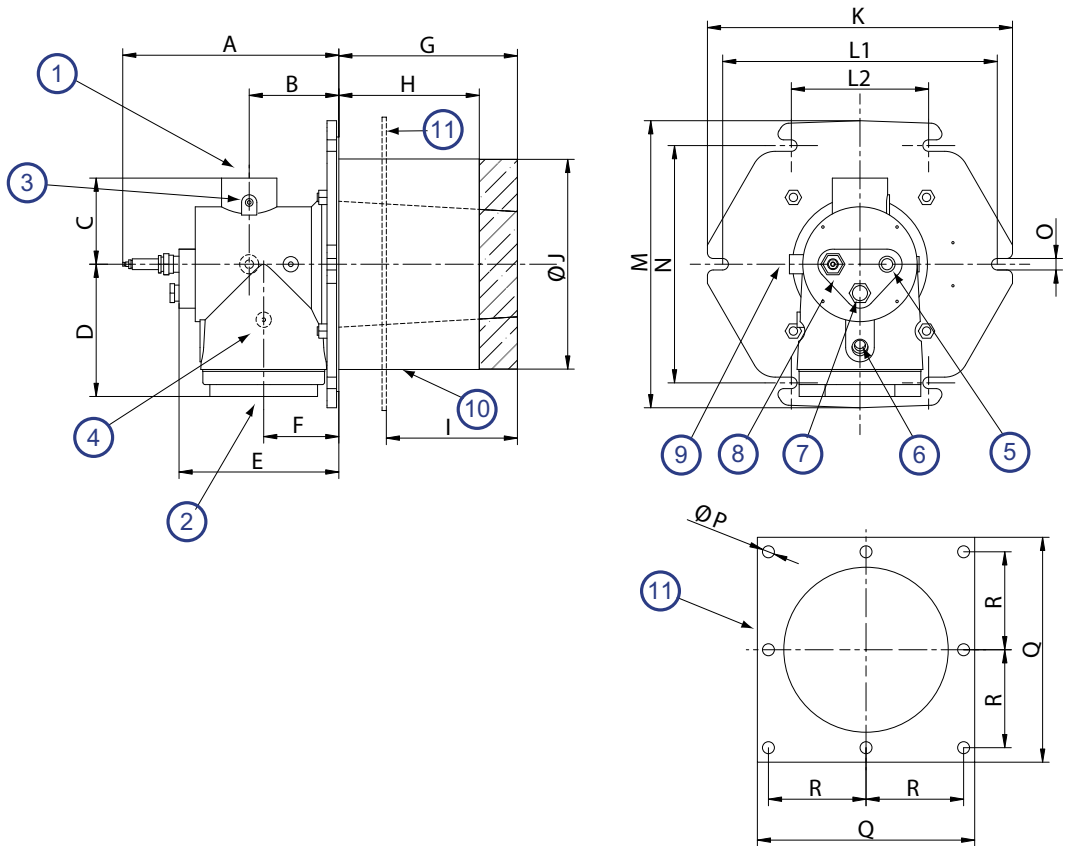

Dimensions in mm unless stated otherwise																			
Burner size	gas inlet		air inlet [2]		A [1]	B	C	D	E	F	K	L1	L2	M	N	O	P Ø	Q	R
	ANSI (NPT)	ISO (Rp)	ANSI (NPT)	ISO (Rp)															
3"	1.1/2	1.1/2	3	3	365	113	106	162	187	84	381	340	168	356	295	15	16	337	149
4"	2	2	4	4	407	122	114	178	217	103	406	365	183	381	314	15	16	359	160

[1] includes clearance for removal.

[2] optional welding flanges are available.

Dimensions in mm unless stated otherwise																	
Burner size	Carbon steel block sleeve					Stainless steel block sleeve					Stainless steel long block sleeve					Stainless steel sleeve (no block)	
	Standard block					Standard block					Extended block					G	J Ø
	G	H	I min	I max	J Ø	G	H	I min	I max	J Ø	G	H	I min	I max	J Ø		
3"	235	57	178	184	257	235	184	51	184	257	343	254	89	292	257	241	137
4"	235	57	178	184	280	235	184	51	184	280	343	254	89	292	280	241	174

KINEMAX[®] Size 6 – type G

Gas only

- 1) Gas inlet
- 2) Combustion air inlet with optional flange (threaded or welding flange)
- 3) Gas pressure test connection
- 4) Combustion air pressure test connection
- 5) Flame supervision port 1/2" (NPT or ISO)
- 6) Alternate scanner connection 1/2" (NPT or ISO)
- 7) Sight glass
- 8) Sparkignitor
- 9) Pilot gas inlet 3/8" (NPT or ISO)
- 10) Optional block sleeve (stainless steel)

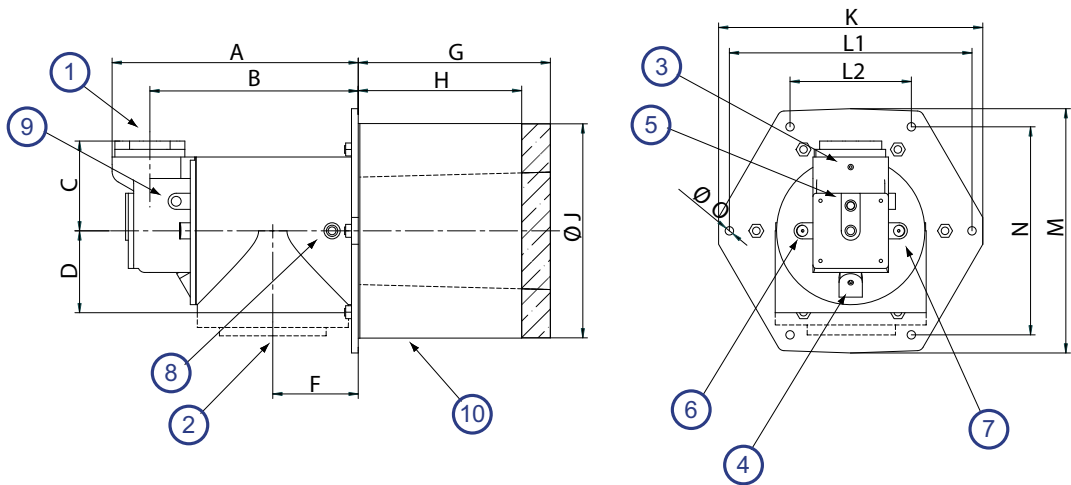

Dimensions in mm unless stated otherwise

gas inlet		air inlet [1]		A	B	C	D	F	G		H	J Ø		K	L1	L2	M	N	O
ANSI (NPT)	ISO (Rp)	ANSI (NPT)	ISO (Rp)						std. block	sleeve		block	sleeve						
3	3	6	6	463	394	167	155	160	362	318	305	407	213	498	457	229	463	394	16

[1] 6" combustion air inlet flange available in either threaded or welding flange version.

KINEMAX[®] Size 2 – type C

Gas/oil

- 1) Gas inlet
- 2) Combustion air inlet
- 3) Atomizing air connection
- 4) Oil inlet
- 5) Gas pressure test connection
- 6) Combustion air pressure test connection
- 7) Pilot gas inlet 3/8" (NPT or ISO) - other side
- 8) Spark ignitor - other side
- 9) Flame supervision port 1/2" (NPT or ISO)
- 10) Alternate scanner connection 1/2" (NPT or ISO)
- 11) Sight glass
- 12) Optional block sleeve (stainless steel)
- 13) Optional mounting plate (only in combination with optional block sleeve)

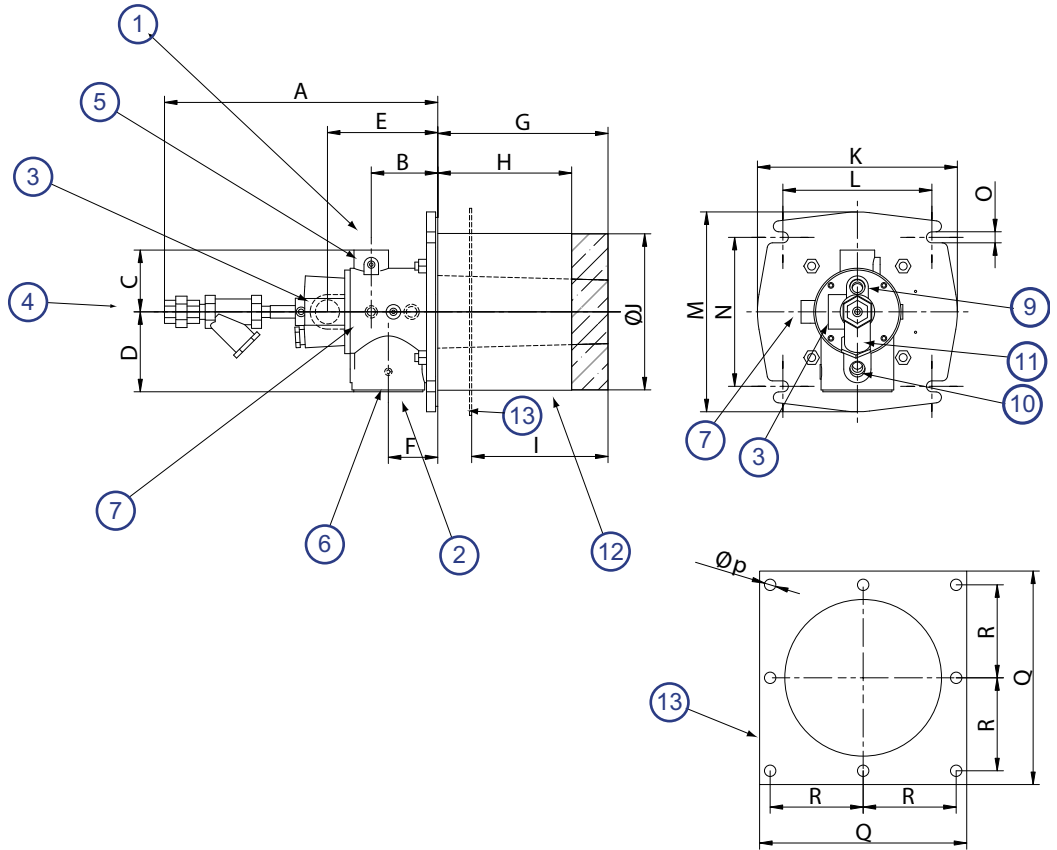

Dimensions in mm unless stated otherwise																						
gas inlet [2]		combustio n air inlet [2]		atomizing air inlet		oil inlet		A [1]	B	C	D	E	F	K	L	M	N	O	P	Ø	Q	R
ANSI (NPT)	ISO (Rp)	ANSI (NPT)	ISO (Rp)	ANSI (NPT)	ISO (Rp)	ANSI (NPT)	ISO (Rp)															
1	1	2	2	1	1	1/4	1/4	382	94	86	110	154	70	280	208	280	209	15	16	299	130	

[1] add 500 mm for retraction.

[2] gas and air inlet flanges are available with ISO or NPT thread or as welding flange.

Dimensions in mm unless stated otherwise														
Carbon steel block sleeve					Stainless steel block sleeve					Stainless steel long block sleeve				
Standard block					Standard block					Extended block				
G	H	I min	I max	Ø J	G	H	I min	I max	Ø J	G	H	I min	I max	Ø J
235	57	178	184	219	235	184	51	184	219	343	254	89	292	219

KINEMAX[®] Size 6 – type C

Gas/oil

- 1) Gas inlet
- 2) Combustion air inlet
- 3) Atomizing air connection
- 4) Oil inlet
- 5) Gas pressure test connection
- 6) Combustion air pressure test connection
- 7) Pilot gas inlet 3/8" (NPT or ISO)
- 8) Spark ignitor
- 9) Flame supervision port 1/2" (NPT or ISO)
- 10) Sight glass
- 11) Alt. flame supervision port 3/4" (NPT or ISO)
- 12) Optional block sleeve (stainless steel)

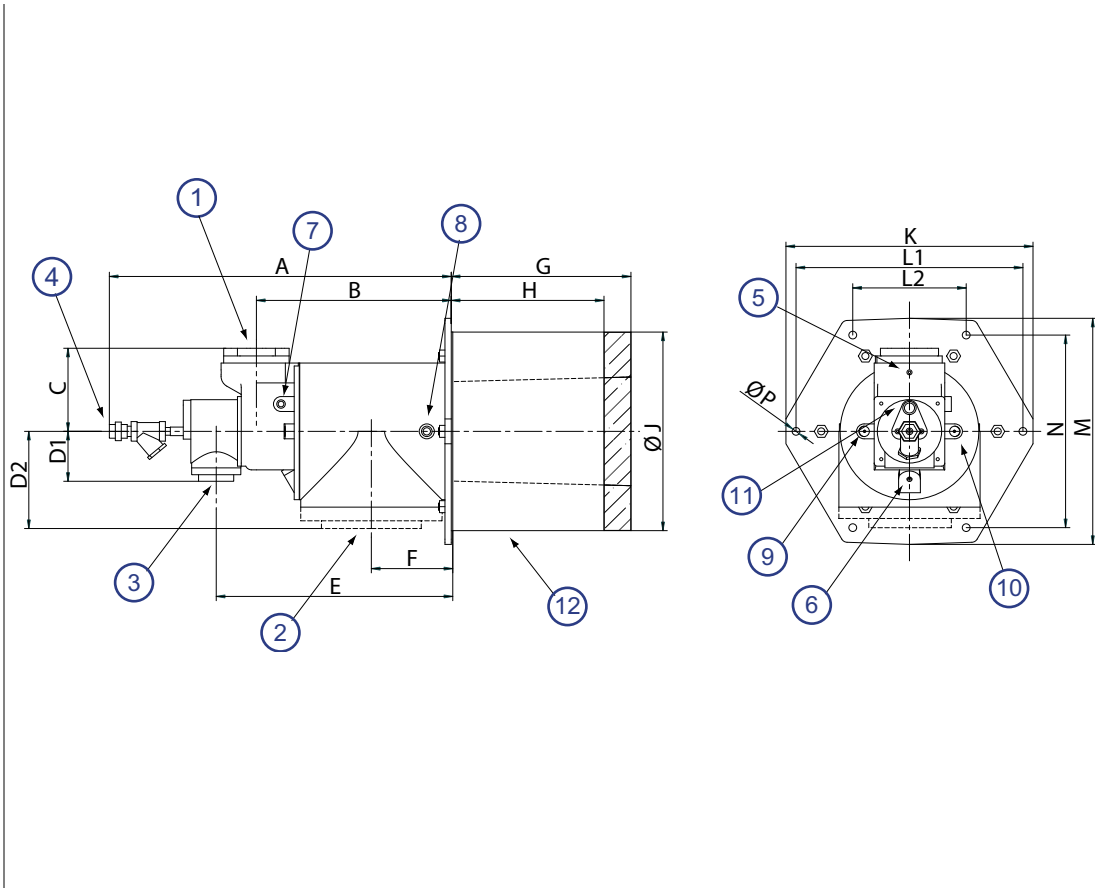

Dimensions in mm unless stated otherwise																					
gas inlet [2]		combustion air inlet [2]		atomizing air inlet		oil inlet		A [1]	B	C	D1	D2	E	F	K	L1	L2	M	N	P Ø	
ANSI (NPT)	ISO (Rp)	ANSI (NPT)	ISO (Rp)	ANSI (NPT)	ISO (Rp)	ANSI (NPT)	ISO (Rp)														
3	3	6	6	2	2	3/8	3/8	692	394	167	102	197	478	160	498	457	229	462	394	15	

[1] add 500 mm for retraction.

[2] gas and air inlet flanges are available with ISO or NPT thread or as welding flange.

Dimensions in mm unless stated otherwise				
Stainless steel block sleeve			Stainless steel long block sleeve	
Standard block			Extended block	
G	H	J Ø	G	J Ø
362	305	406	318	213

Spark ignitor and flame rod

Spark ignitor

- 1) O-ring
- 2) 1/2" NPT
- 3) wrench size 24 mm
- 4) wrench size 21 mm"
- 5) Spark disk, only on 3-G and 4-G sizes.

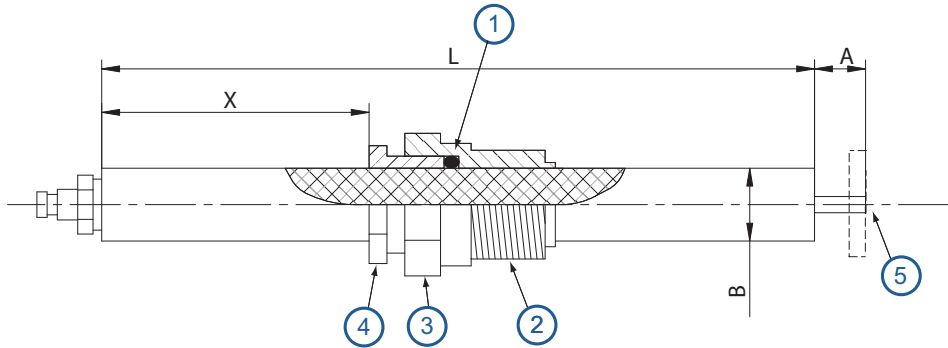

Dimensions in mm unless stated otherwise				
Burner size	X	L	A	B
1.5-G	30	165	12.7	14.2
2-G	30	165		
2-C	30	89	6.4	
3-G	52	210	12.7	
4-G	37	210	12.7	
6-G	fit to burner	140	12.7	
G-C	fit to burner	140		

Flame rod

- 1) O-ring
- 2) Rc 1/2" NPT
- 3) wrench size 24 mm
- 4) wrench size 21 mm

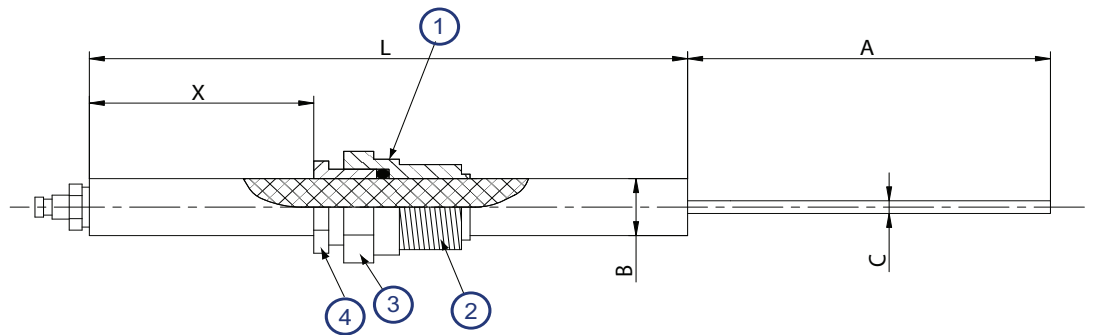

Dimensions in mm unless stated otherwise					
Burner size	X	L	A	B	C
1.5	59	191	114	14	5
2	59	191	114	14	5
3	83	235	114	14	7
4	71	235	203	14	7



Please read the operating and mounting instructions before using the equipment. Install the equipment in compliance with the prevailing regulations.

Bedrijfs- en montagehandleiding voor gebruik goed lezen! Apparaat moet volgens de geldende voorschriften worden geïnstalleerd.

Lire les instructions de montage et de service avant utilisation! L'appareil doit impérativement être installé selon les réglementations en vigueur.

Betriebs- und Montageanleitung vor Gebrauch lesen! Gerät muß nach den geltenden Vorschriften installiert werden.

MANUFACTURER AND IMPORTER ADDRESSES

Below are the addresses and contact information for the Honeywell – Maxon manufacturing location and European sales office. The European sales office serves as the importer and EU manufacturer's representative under the EU New Legislative Framework (NLF).

MUNCIE, INDIANA, USA – MANUFACTURER

201 East 18th Street
P.O. Box 2068
Muncie, IN 47307-0068
Tel: 765.284.3304
Fax: 765.286.8394

EUROPEAN SALES OFFICE – IMPORTER

BELGIUM
Maxon International BVBA
Luchthavenlaan 16-18
1800 Vilvoorde, Belgium
Tel: 32.2.255.09.09
Fax: 32.2.251.82.41

INSTALLATION AND OPERATION INSTRUCTIONS FOR KINEMAX® BURNERS

Application requirements

View port

A view port to observe burner flame is essential to inspect the flame aspect. Locate the view port downstream of the flame, looking back to the burner block. Make sure the complete flame can be evaluated.

Supporting burner air and gas piping

The KINEMAX® burner shall not be used as support for the piping to the burner. Gas and air piping shall be supported in such way that no additional loads will be created on the burner.

Burner mounting flange loads

Check burner weight and reinforce burner mounting flange or combustion chamber/furnace back wall if necessary to take the complete burner weight.

INSTALLATION INSTRUCTIONS

Storage of KINEMAX® burners

KINEMAX® burners shall be stored dry (inside). Burner blocks have been cured carefully before shipment and shall be kept dry. Wetting of the blocks could result in premature failures.

Handling of KINEMAX® burners

KINEMAX® burners are shipped as complete units. Handle burners with care, using proper equipment during unpacking, transport, lifting and installation. **Any impact on the burner could result in damage.** To prevent damage in transit, accessories such as flame rods, control valves and/or UV-scanners, may be packed separately and shipped loose.

Flange the burner to the installation

Bolt the burner to the installation's burner mounting flange. Use proper MAXON optional gaskets. Tighten the flange bolting with correct torque. Retighten all bolts after first firing and regularly after commissioning.

- 1) Insulation
- 2) Housing
- 3) Gasket (optional)
- 4) Mounting studs
- 5) Burner

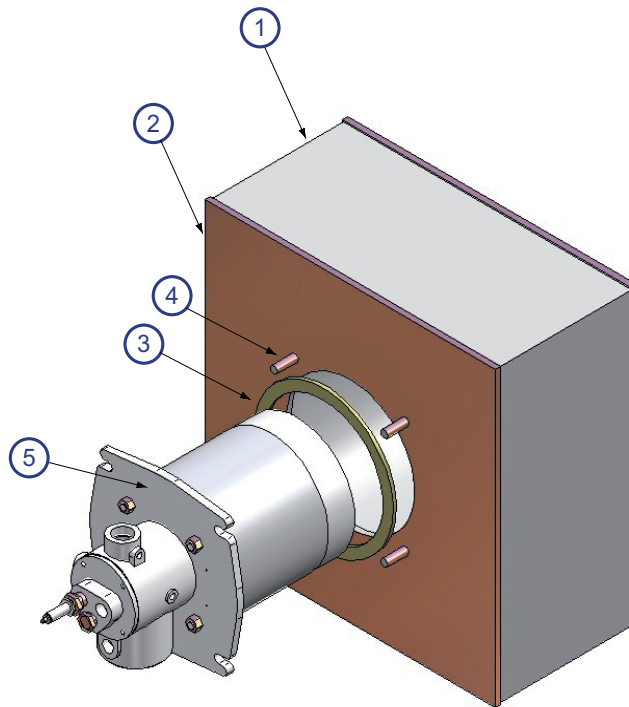

KINEMAX® with standard block

- 6) Insulation
- 7) Housing
- 8) Gasket (optional)
- 9) Mounting studs
- 10) Burner

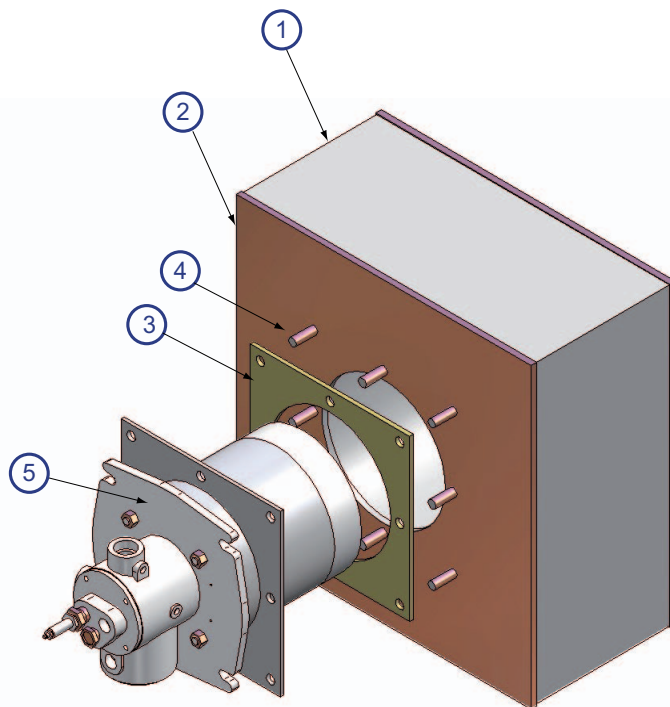

KINEMAX® with optional mounting flange

Furnace / combustion chamber requirements

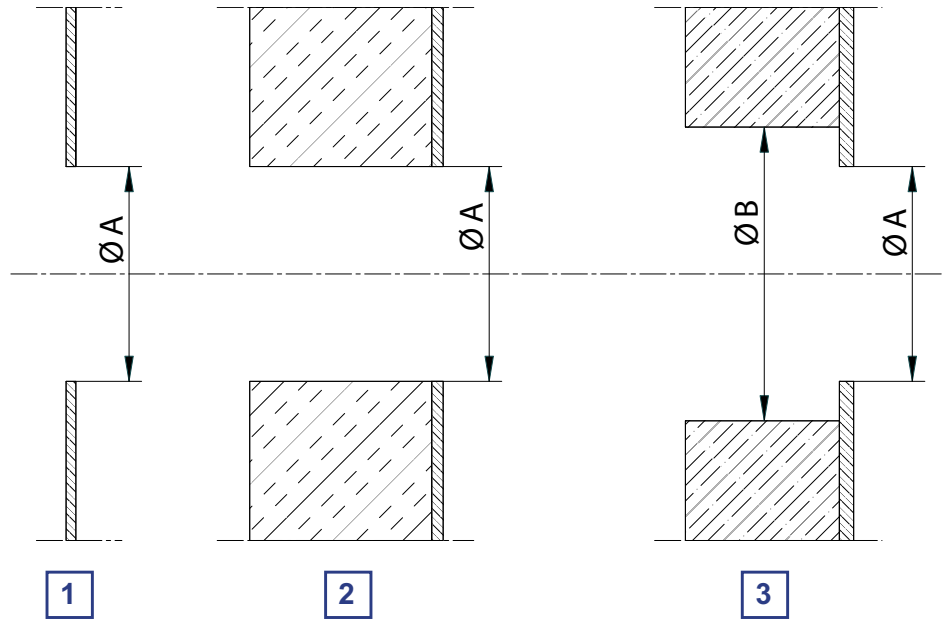

Sketch 1 : sheet metal combustion chamber/furnace without internal insulation. Flange/opening internal diameter shall be ØA

Sketch 3 : furnace or ovens with brick walls: opening in brick wall shall be ØB (to be rammed with castable refractory)

Sketch 2 : sheet metal combustion chamber/furnace with soft wall internal insulation. Flange/opening internal diameter shall be ØA

Dimensions in mm unless stated otherwise					
Burner size	1.5	2	3	4	6
KINEMAX® WITH REFRACTORY BLOCK					
Ø A	229	229	267	289	417
Ø B	369	369	407	429	557
KINEMAX® WITH OPTIONAL STAINLESS STEEL DISCHARGE SLEEVE					
Ø A	112	118	147	184	N/A
Ø B	252	258	287	324	N/A

Refractory wall : Standard blocks

KINEMAX® burners with standard blocks (without supporting sleeve) require supporting of the burner block by the furnace wall. Ram the gap between block and furnace with castable refractory.

- 1) KINEMAX® burner with standard block
- 2) Furnace shell
- 3) MAXON gasket (optional)
- 4) Burner refractory block
- 5) Castable refractory, rammed into the space around the burner block
- 6) Furnace refractory wall

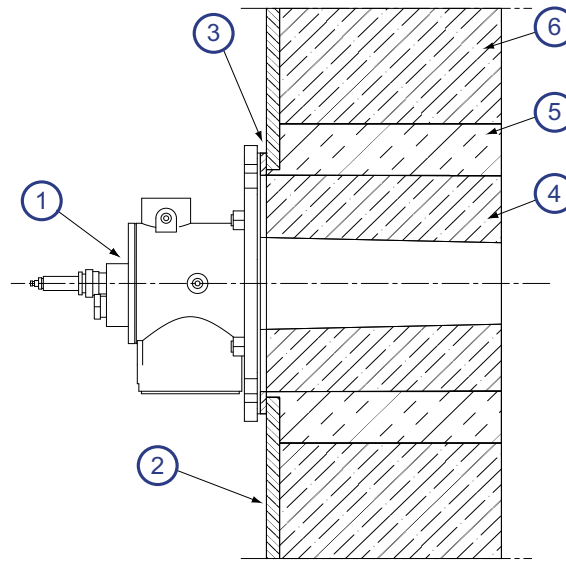

Furnace wall with soft insulation : Blocks with supporting sleeve

KINEMAX® burners which are mounted in a furnace wall with soft insulation, need to have a burner block sleeve (optional) specified. This sleeve makes the burner block

self supporting. Remaining space between burner block and insulated wall should be packed tightly with ceramic fibre insulation.

- 7) KINEMAX® burner with block and optional block sleeve
- 8) Furnace shell
- 9) MAXON gasket (optional)
- 10) Burner refractory block with optional sleeve
- 11) Fibre insulation, fitted into the space around the burner block
- 12) Furnace fibre insulation

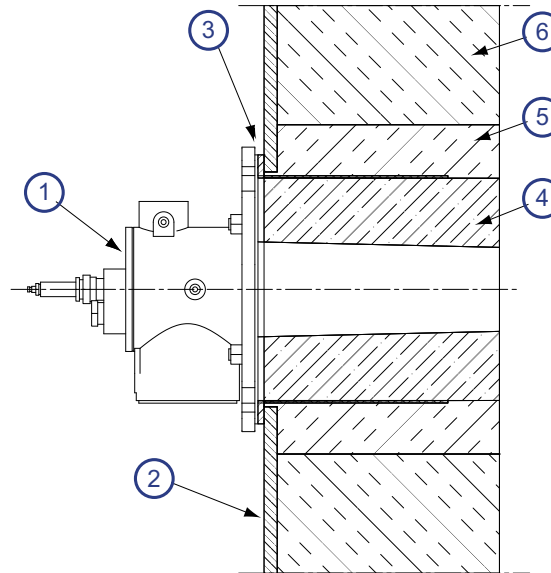

Installation of a replacement block sub-assembly

- Secure heat processing equipment from operation following manufacturer's instructions.
- Disconnect piping, etc. and remove KINEMAX® Burner from installation.

- Loosen and remove the nuts holding the burner body to the burner block.
- Remove old block assembly and remount new block assembly. Be sure gasket between block and body is in place between the components.

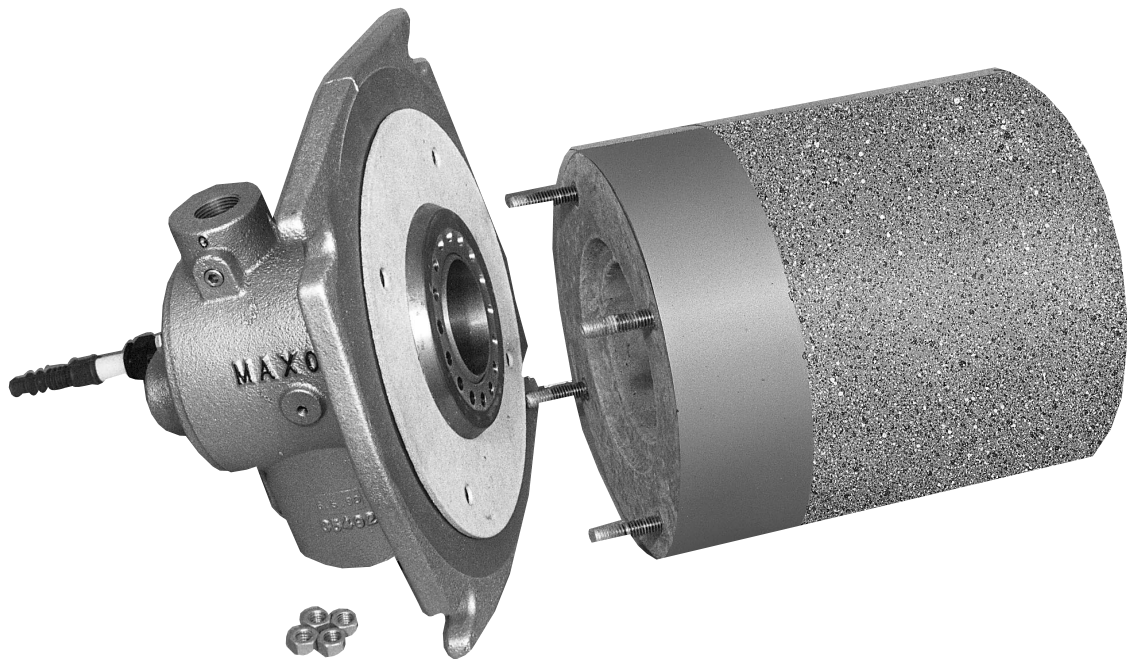

START-UP INSTRUCTIONS FOR KINEMAX® BURNERS

Instructions provided by the company or individual responsible for the manufacture and/or overall installation of a complete system incorporating MAXON burners take precedence over the installation and operating instructions provided by MAXON. If any of the instructions provided by MAXON are in conflict with local codes or regulations, please contact MAXON before initial start-up of equipment.



CAUTION

Read the combustion system manual carefully before initiating the start-up and adjustment procedure. Verify that all of the equipment associated with and necessary to the safe operation of the burner system has been installed correctly, that all pre-commissioning checks have been carried out successfully and that all safety related aspects of the installation are properly addressed.

Initial adjustment and light-off should be undertaken only by a trained commissioning engineer.

First firing or restart after shut-down

During first start-up of the burner, allow extended period at low firing range to minimize potential damage from accumulated and retained moisture in refractory burner block.

During cold starts, the temperature rise shall be limited – allow the burner to fire on low fire for some time to allow the parts to heat up slowly for maximum life.

Safety interlocks

Guarantee that all the required safety locks as described in the applicable local codes or regulations, or supplementary safety locks requested for safe operation of the overall installation, are working properly and resulting in a positive safety-lock of the burner. Do not bypass any of these safety interlocks. This will result in unsafe operation.

Checks during and after start-up

During and after start-up, check the integrity of the system. Check all bolted connections after first firing (first time on temperature) and retighten if necessary.

Purge

For safety reasons, it is required to purge the installation sufficiently long to ensure that all possible combustibles are evacuated before ignition. Refer to the applicable local codes and your specific application requirements to determine the purge time.

Pilot ignition

Adjust pilot air flow and pilot gas regulator to correct set point before pilot ignition attempt. Turn adjustable orifice screw out (counter-clockwise) several turns from its fully seated position. Refine during lighting of the pilot to a yellow/blue flame and/or strongest stable flame signal.

Main burner ignition

Adjust the main gas regulator at the correct set point before igniting the main burner. Ensure that the gas/air ratio valve is in the start position when lighting the main burner.

After ignition of main burner, allow some time on minimum capacity to allow the burner parts to heat up slowly.

Ratio adjustment

Once the main flame is ignited, adjust air/gas ratio of the burner to have the required combustion quality. Slowly increase capacity while observing the flame. Do not increase capacity too fast to avoid damage to burner parts or furnace due to excessive temperature gradient.

For More Information

The Honeywell Thermal Solutions family of products includes Honeywell Combustion Safety, Eclipse, Exothermics, Hauck, Kromschröder and Maxon. To learn more about our products, visit ThermalSolutions.honeywell.com or contact your Honeywell Sales Engineer.

Honeywell MAXON branded products

201 E 18th Street
Muncie, IN 47302
USA

www.maxoncorp.com

Honeywell Process Solutions

Honeywell Thermal Solutions (HTS)
1250 West Sam Houston Parkway
South Houston, TX 77042
ThermalSolutions.honeywell



WARNING

Oil flames are highly radiant.

Use eye protection and avoid prolonged viewing.

MAINTENANCE AND INSPECTION

Safety requirements

Regular inspection, testing and recalibration of combustion equipment according to the installation's manual are an integral part of its safety. Inspection activities and frequencies shall be carried out as specified in the installation's manual. Perform the following activities at least annually as part of a recommended preventative maintenance routine:

- Inspect burner internal parts for wear and oxidation, paying special attention to the refractory of the burner block (when applicable).
- Inspect associated control instruments and devices for function with particular attention to all safety permissive switches.
- Perform leak tests on fuel shut off valves according to any schedule established by the authority having jurisdiction.

Visual inspections

Regular visual inspection of all connections (air and gas piping to the burner, bolting of the burner mounting flange) and burner flame shape and aspect are essential for safe operation.

Recommended spare parts

Keep local stock of spark ignitor. It is not recommended to keep local stock of other burner parts. Consult installation manual for burner spare parts and system accessories.