

Typical Piping Layouts for PREMIX® Blower Mixer Systems

Block & Bleed system is frequently required by insurance authorities.

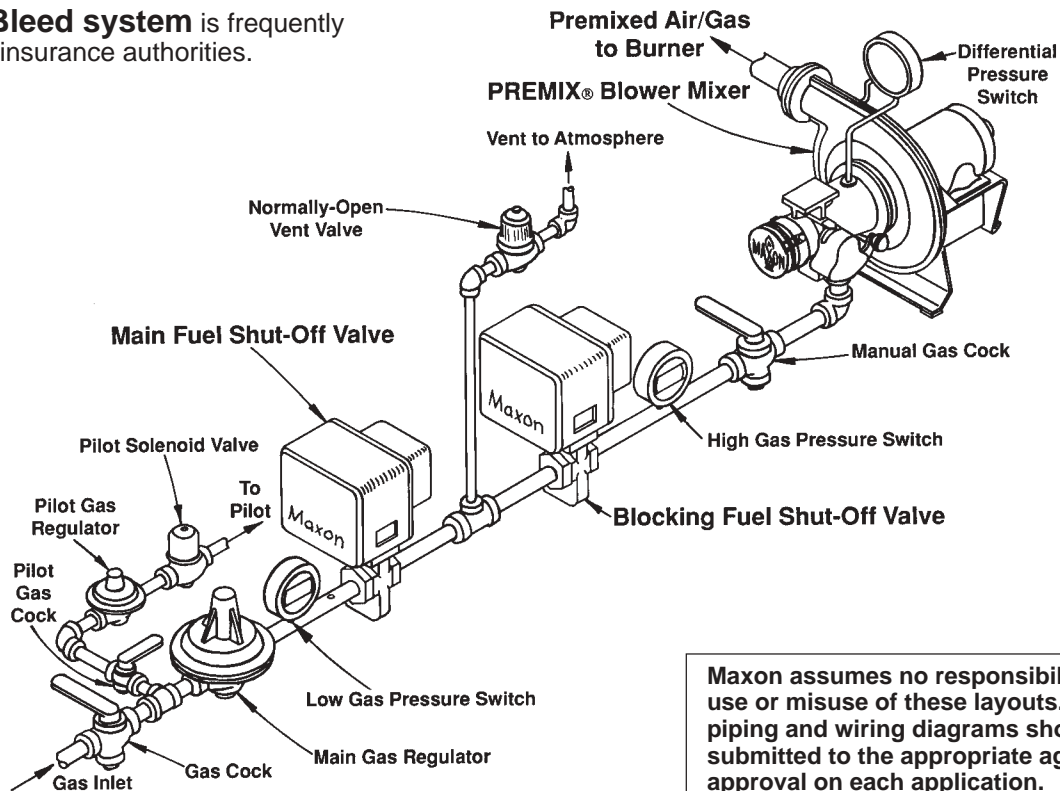

Maxon assumes no responsibility for the use or misuse of these layouts. Specific piping and wiring diagrams should be submitted to the appropriate agencies for approval on each application.

Stand-by fuel arrangements permit quick changeover to alternate fuels.

Maxon Series "Q" Flow Control Valves described in catalog Bulletin 7000 provide the additional flow control point for the stand-by fuel arrangements.



A single control operator (rated for at least 150 inch-pounds torque) operates both the ratio valve furnished as part of the PREMIX® Blower Mixer and an additional Series "Q" Control Valve (ordered separately). Typical piping arrangement is shown at right. Maxon does not supply the piping shown.

When this arrangement is used, the PREMIX® Blower Mixer is first adjusted for the primary fuel (usually natural gas), then the "Q" Valve is adjusted to provide proper alternate fuel flow.

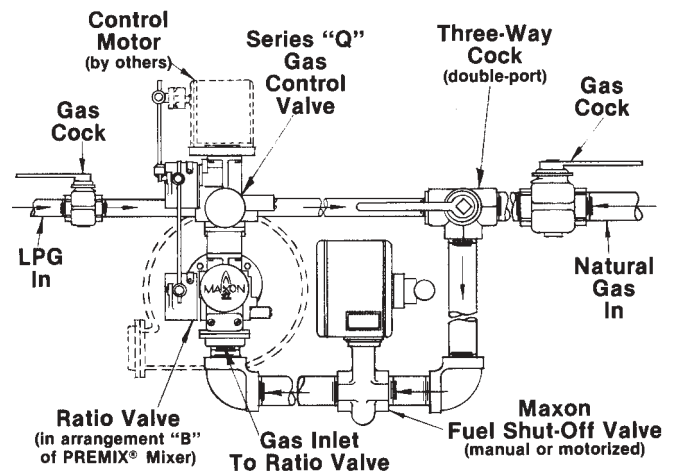

A complete burner system utilizing a PREMIX® Blower Mixer will also include gas train, burner assembly and control panel. Your Maxon representative can help you choose from the broad range available.

Capacity/Selection Data

PREMIX® Blower Mixers

General

The capacity of a PREMIX® Blower Mixer is determined by the size, type, and number of burners or nozzles, and by the field conditions under which it operates. Choose carefully from the capacities/selection tables for the combination of mixer, burner and operating conditions for your application.

Slight variations in combustion chamber pressure, draft conditions, or the availability of secondary air can affect ratings and performance.

Each blower mixer must be matched to total discharge areas and mixture pressure requirements of the specific burners used. Four types of blower mixers are available: M, PL, PM and PH.

Miniature PREMIX® Blower Mixers are for "on-off" firing applications and do not include a ratio valve.

PL Mixers use smaller motors and develop less mixture pressure than PM Mixers. PH Mixers develop the highest mixture pressures.

Designations of PREMIX® Blower Mixers

PREMIX® Blower Mixer designations consist of two parts. The first half of the designation represents the mixer type. For "M", "PL", "PM" and "PH" Mixers, this is followed by their maximum capacity (in thousands of Btu/hr) when firing a single STICKTITE™ Nozzle against balanced conditions.

Example: **PM-525** PREMIX® Blower Mixer has a maximum capacity of 525,000 Btu/hr when firing a single HD- 2" -21 STICKTITE™ Nozzle in open air or against a balanced combustion chamber static pressure condition.

An **M-500** Miniature PREMIX® Blower Mixer has a capacity of 500,000 Btu/hr with a HD - 2-1/2" -27 STICKTITE™ Nozzle in similar conditions.

Each PREMIX® Blower Mixer assembly includes a totally enclosed electric motor. You may select from a variety of available voltages:

Horsepower	60 Hertz Options			50 Hertz Options (possible net extra cost)		
	115/208 - 230/1/60	208 - 230/460/3/60 (standard motor)	575/3/60	190 - 200/1/50	380 - 415/3/50	500/3/50
1/6	√	Not Available	Not Available	√	Not Available	Not Available
1/3 & 1/2	√	√	√	√	√	√
3/4 & 1	√	√	√	√	√	√
1-1/2, 2, 3 & 5	Not Available	√	√	Not Available	√	√

Capacity/Selection Data

PREMIX® Blower Mixers with STICKTITE™ Nozzles

This page provides sizing and capacity information for systems using PREMIX® Blower Mixers and STICKTITE™ and/or PILOTPAK™ Burner Nozzles.

Capacities (in 1000's Btu/hr) shown in Tables 3, 4, and 5 are based on firing through appropriately-sized Series "T" Tuyere Blocks into a combustion chamber whose internal pressure does not exceed +0.05".

Higher back pressures reduce capacities by the percentages shown in **Table 1** at right.

Suction conditions with adequate secondary air may allow capacity increases by the percentages shown in **Table 2**.

To select a mixer and burner combination, determine required maximum capacity. Use tables below to find nozzle size and mixer designation.

Multiple nozzles can be used, but the actual capacities will depend upon the type, size, and quantity of nozzles selected for your application.

Table 1: Percent of capacity reduction

Back Pressure		+0.1" wc	+0.15" wc	+0.2" wc	+0.25" wc
Percent Reduction	PL	3	6	9	12
	PM	2-1/2	5	7-1/2	10
	PH	2	4	6	8

Table 2: Percent of capacity increase

Application		Oven & Furnace		Immersion Tube	
Suction		-0.05" wc	-0.1" wc	-0.05" wc	-0.1" wc
Percent Increase	PL	6	12	12	24
	PM	5	10	10	20
	PH	4	8	8	16

PREMIX® Blower Mixer Capacities (1000's Btu/hr) with STICKTITE™/PILOTPAK™ Nozzle firing into balanced combustion chamber pressure (0 to +0.05" wc static pressure)

Table 3: "PL" Blower Mixers

Mixer Size	Nozzle	
	Size	Max:Min
PL-80	1" -9	80:25
PL-130	1-1/4" -12	130:40
PL-165	1-1/4" -14	165:60
PL-195	1-1/2" -16	195:75
PL-380	1-1/2" -18	380:100
PL-490	2" -21	490:110
PL-540	2" -24	540:170
PL-630		630:170
PL-750	2-1/2" -27	750:200
PL-850	3" -30	850:240
PL-1000	4" -34	1000:275
PL-1350	4" -41	1350:450
PL-1440		1440:450
PL-1700		1700:450
PL-2650	5" -50	2650:700
PL-3500	6" -60	3500:1100
PL-4250		4250:1100
PL-4600		4600:1100

Table 4: "PM" Blower Mixers

Mixer Size	Nozzle	
	Size	Max:Min
PM-200	1-1/4" -12	200:40
PM-260	1-1/4" -14	260:60
PM-350	1-1/2" -16	350:75
PM-525	2" -21	525:110
PM-690	2" -24	690:170
PM-920	2-1/2" -27	920:200
PM-1080	3" -30	1080:240
PM-1200	4" -34	1200:275
PM-2000	4" -41	2000:450
PM-3200	5" -50	3200:700

Table 5: "PH" Blower Mixers

Mixer Size	Nozzle	
	Size	Max:Min
PH-190	1-1/4" -10	190:30
PH-250	1-1/4" -12	250:40
PH-330	1-1/4" -14	330:60
PH-400	1-1/2" -16	400:75
PH-500	1-1/2" -18	500:100
PH-700	2" -21	700:110
PH-900	2" -24	900:170
PH-1220	2-1/2" -27	1220:200
PH-1400	3" -30	1400:240
PH-1650	4" -34	1650:275
PH-2350	4" -41	2350:450

Capacity/Selection Data

Miniature PREMIX® Blower Mixers with STICKTITE™ Nozzles

The table below provides performance data for Miniature PREMIX® Blower Mixers used with STICKTITE™ Burner Nozzles. All minimum capacities are based on natural gas firing at 0.25" wc differential mixture pressure.

Two maximum capacities are shown. The “**on-ratio**” **maximum** is attainable when firing against balanced pressure conditions and requires 3" wc natural gas pressure at blower mixer inlet. Maximum capacities will be reduced by 5 to 50% when the M-

500 unit is fired against +0.15" wc to +0.75" wc back pressure (+0.15" wc to +0.5" wc for other sizes). **Do not use against higher back pressures.**

The **rich maximum capacity** shown requires at least 6" wc gas pressure at blower mixer inlet, and is attainable only when firing in open air.

Data given for single STICKTITE™ Nozzles lists the flame length that may be expected under rich maximum firing conditions. Flame will be shorter under all other circumstances.

Mixer Designation	Capacity (1000's Btu/hr)			Maximum Mixture Pressure (inches wc)	STICKTITE™ Nozzle	
	Minimum	On-Ratio Maximum	Rich Maximum		Size	Approximate Flame Length (in inches)
M-100	18	39	50	1.3	HD-3/4" -7	8
	21	44	70	1.25	HD -1" -8	10
	25	54	120	1.2	HD -1" -9	12
	31	65	130	1.1	HD -1-1/4" -10	14
	40	85	140	1	HD -1-1/4" -12	16
	60	98	150	0.75	HD -1-1/4" -14	18
M-250	75	150	270	1.1	HD -1-1/2" -16	38
	100	180	370	1	HD -1-1/2" -18	50
	110	225	450	0.9	HD -2" -21	60
M-500	170	360	600	1.35	HD -2" -24	54
	200	500	820	1.6	HD -2-1/2" -27	60
	240	580	1000	1.5	HD -3" -30	65
	275	670	1200	1.4	HD -4" -34	65

Capacity/Selection Data

PREMIX® Blower Mixers with Series “SN” Sealed Nozzles

This page provides sizing and capacity information for systems using PREMIX® Blower Mixers and “SN” Sealed Nozzles. Data is based on balanced conditions or less than +0.05" wc combustion chamber pressure.

Suctions or drafts of up to 0.1" wc will have no appreciable affect on capacity since these are sealed burners. Higher back pressures reduce capacities by the percentages shown in **Table 1** at right.

To select a mixer and burner combination, determine required maximum capacity. Use tables below to find nozzle size and mixer designation.

Multiple nozzles can be used but the actual capacities will depend upon the type, size and quantity of nozzles selected for your application.

Table 1: Percent of capacity reduction

Back Pressure		+1" wc	+1.5" wc	+2" wc	+2.5" wc
Percent Reduction	PL	2-1/2	5	7-1/2	10
	PM	2	3	4	5
	PH	2	3	4	5

PREMIX® Blower Mixer Capacities (1000’s Btu/hr) with “SN” Sealed Nozzles firing into balanced combustion chamber pressure (0 to +0.05" wc static pressure)

Table 2: "PL" Blower Mixers

Mixer Size	Nozzle	
	Size	Max:Min
PL-80	1" -9	80:25
PL-130	1-1/4" -12	130:40
PL-165	1-1/4" -14	165:60
PL-195	1-1/2" -16	195:75
PL-380	1-1/2" -18	380:100
PL-490	2" -20	490:155
PL-540	2" -24	540:170
PL-630		630:170
PL-750	2-1/2" -27	750:200
PL-850		850:200
PL-1000	3" -33	1000:360
PL-1350	4" -42	1350:560
PL-1440		1440:560
PL-1700		1700:560
PL-2650	4" -45	2650:720
PL-3500	6" -60	3500:1100
PL-4250		4250:1100
PL-4600		4600:1100

Table 3: "PM" Blower Mixers

Mixer Size	Nozzle	
	Size	Max:Min
PM-200	1-1/4" -12	200:40
PM-260	1-1/4" -14	260:60
PM-350	1-1/2" -16	350:75
PM-525	2" -20	525:160
PM-690	2" -24	690:170
PM-920	2-1/2" -27	920:200
PM-1080		1080:200
PM-1200	3" -33	1200:360
PM-2000	4" -42	2000:560
PM-3200		3200:560

Table 4: "PH" Blower Mixers

Mixer Size	Nozzle	
	Size	Max:Min
PH-190	1" -9	190:25
PH-250	1-1/4" -12	250:40
PH-330	1-1/4" -14	330:60
PH-400	1-1/2" -16	400:75
PH-500	1-1/2" -18	500:100
PH-700	2" -20	700:160
PH-900	2" -24	900:170
PH-1220	2-1/2" -27	1220:200
PH-1400		1400:200
PH-1650	3" -33	1650:360
PH-2350	4" -42	2350:560

Capacity/Selection Data

PREMIX® Blower Mixers with Style "A" or "B" LINOFLAME® Burners

Information is provided on this page and page 3109 for systems using PREMIX® Blower Mixers and Style "A" or "B" LINOFLAME® Burners firing in still air.

Capacities shown in the tables are based on 100% air/gas premixture through the burner and on minimal use of secondary air. Maximum capacity may be reduced as much as 10% if fresh air is restricted.

These tables are also based on balanced pressure conditions and the use of a regulated supply of natural gas at 2" -7" wc (measured at blower mixer inlet).

Low-fire start is recommended for all such applications, and particularly with Type "PH" Mixers, because of the higher mixture pressures developed.

To select a mixer and burner combination, determine your required maximum capacity. When you locate suitable capacities, read the required PREMIX® Mixer size from left side of the table. Choose any of the burner footage/drilling combinations shown to the right of capacity columns, matching the footage to your space available and heat distribution needs.

LINOFLAME® Burner assemblies can be shaped to meet the needs of your particular application (for additional burner information, see Maxon catalog section pertaining to LINOFLAME® Burners).

Table 1: Capacities (1000's Btu/hr) with "PL" Blower Mixers and indicated footage of Style "A" or "B" LINOFLAME® Burner in still air applications [1]

Blower Mixer Designation	Capacities (1000's Btu/hr)		Style "A" or "B" LINOFLAME® Burner assembly length (feet-inches of indicated type and drillings)					
	Maximum	Minimum	B-36-42-42	B-96-50-50	B-96-44-44	B-96-36-43	A-72-17-33	A-72-C-33
PL-80	80	20	1'	---	---	---	---	---
PL-130	130	45	1' 10"	1' 6"	1' 3"	1'	---	---
PL-165	165	66	2' 6"	2' 3"	2'	1' 3"	---	---
PL-195	195	78	3' 4"	2' 8"	2' 3"	1' 8"	1'	---
PL-380	380	105	4'	3' 6"	2' 8"	2'	1' 6"	1'
PL-490	490	165	6' 3"	5' 6"	4' 3"	3'	2'	1' 6"
PL-540	540	175	7' 6"	6' 3"	5'	3' 8"	---	---
PL-630	630	185	6' 10"	5' 10"	4' 6"	3' 3"	2'	1' 6"
PL-750	750	210	8' 8"	7' 4"	5' 8"	4'	2' 8"	2'
PL-850	850	285	11' 3"	9' 6"	7' 4"	5' 4"	3' 6"	2' 6"
PL-1000	1000	330	13' 3"	11'	8' 6"	6' 3"	4'	3'
PL-1350	1350	450	18'	15'	12'	8' 6"	5' 8"	4'
PL-1440	1440	465	18' 4"	15' 8"	12'	8' 8"	6'	4'
PL-1700	1700	520	20' 3"	17' 4"	13' 4"	10'	6' 6"	4' 6"
PL-2650	2650	730	29'	24' 3"	19'	13' 8"	9'	6' 6"
PL-3500	3500	1130	45'	38'	29' 8"	21' 6"	14'	10'
PL-4250	4250	1200	43' 4"	37'	28' 6"	20' 8"	14'	10'
PL-4600	4600	1200	44' 9"	37' 6"	27' 8"	21' 6"	14'	10'

[1] LINOFLAME® Burner located in fresh air and subject only to normal convection currents

Capacity/Selection Data

PREMIX® Blower Mixers with Style "A" or "B" LINOFLAME® Burners

Table 2: Capacities (1000's Btu/hr) with "PM" Blower Mixers and indicated footage of Style "A" or "B" LINOFLAME® Burner in still air applications [1]

Blower Mixer Designation	Capacities (1000's Btu/hr)		Style "A" or "B" LINOFLAME® Burner assembly length (feet-inches of indicated type and drillings)					
	Maximum	Minimum	B-36-42-42	B-96-50-50	B-96-44-44	B-96-36-43	A-72-17-33	A-72-C-33
PM-200	160	39	1' 6"	1' 3"	1'	---	---	---
	200	45	2'	1' 6"	1' 8"	1' 2"	---	---
PM-260	260	60	2' 6"	2'	1' 8"	1' 2"	---	---
PM-350	350	88	3' 6"	2' 10"	2' 4"	1' 8"	1'	---
PM-690	690	190	7' 6"	6' 4"	5'	3' 9"	2' 6"	---
PM-920	800	190	7' 6"	6' 4"	5'	3' 8"	2' 6"	---
PM-1080	1050	265	10' 4"	8' 8"	6' 10"	5'	---	2' 6"
PM-1200	1200	310	12' 4"	10' 4"	8' 3"	6'	4'	3'
PM-2000	2000	510	20'	16' 8"	13' 6"	9' 10"	6' 6"	4' 6"
PM-3200	3200	700	27' 4"	23' 4"	18' 4"	13' 4"	9'	6' 6"

[1] LINOFLAME® Burner located in fresh air and subject only to normal convection currents

Table 3: Capacities (1000's Btu/hr) with "PH" Blower Mixers and indicated footage of Style "A" or "B" LINOFLAME® Burner in still air applications [1]

Blower Mixer Designation	Capacities (1000's Btu/hr)		Style "A" or "B" LINOFLAME® Burner assembly length (feet-inches of indicated type and drillings)				
	Maximum	Minimum	B-36-42-42	B-96-50-50	B-96-44-44	B-96-36-43	A-72-17-33
PH-190	190	35	1' 4"	1' 2"	1'	9"	---
PH-250	250	48	1' 10"	1' 8"	1' 3"	1'	---
PH-330	330	68	2' 8"	2' 3"	1' 9"	1' 3"	---
PH-400	400	82	3' 4"	2'	2' 3"	1' 6"	---
PH-500	500	108	4' 4"	3' 8"	3'	2' 2"	1' 6"
PH-700	700	130	5'	4' 3"	3' 4"	2' 4"	---
PH-900	900	180	7'	6'	4' 10"	3' 6"	---
PH-1220	1200	225	8' 6"	7' 4"	5' 8"	4' 3"	---
PH-1400	1400	280	10' 8"	9' 3"	7' 3"	5' 3"	---
PH-1650	1750	390	15' 6"	13' 6"	10' 6"	7' 8"	5'
PH-2350	2300	480	19'	16'	12' 6"	9'	6'
	2800	750	29' 3"	24' 8"	19' 4"	14'	9' 6"

[1] LINOFLAME® Burner located in fresh air and subject only to normal convection currents

Capacity/Selection Data

PREMIX® Blower Mixers with Style “A” or “B” LINOFLAME® Burners

Style “A” or “B” LINOFLAME® Burners may be used in air heating applications with uniform air stream velocities across burner in the range of 500-1500 SFPM and return air temperatures not to exceed 500°F (260°C). A regulated supply of natural gas at 2-7" wc is required to the blower mixer inlet.

At least 25 SCFM fresh make-up air must be available to the recirculated system for each 100,000 Btu/hr of maximum capacity. If not available, use capacities from “still air” tables shown on pages 3108 and 3109.

Capacities of LINOFLAME® Burner assemblies will vary from “still air” capacities when installed for air heating applications. Still air capacities will be increased by 5% when operating in an air stream of 0 to +2.0" wc static pressure. An increase of 10% will be experienced when operating in an air stream with a suction of -1.0 to 0" wc static pressure.

Miniature PREMIX® Blower Mixer with Style “A” or “B” LINOFLAME® Burners

Table 1 below provides capacity data for LINOFLAME® Burner/Miniature PREMIX® Systems.

Two maximum capacities are shown. The **on-ratio maximum** is based on 3" wc natural gas pressure at mixer inlet and balanced pressure firing conditions. Capacities will be reduced by 5% to 50% when the M-

500 unit is fired against +0.15 to +0.75" wc back pressure (+0.15 to +0.50" wc for other sizes). **Do not use against higher back pressures.**

The **rich maximum capacity** shown requires at least 6" wc gas pressure at blower mixer inlet and is attainable only when firing in open air.

Table 1: Capacities (1000's Btu/hr) with Miniature PREMIX Blower Mixers and indicated footage of Style "A" and "B" LINOFLAME® Burners firing into balanced combustion chamber pressure (0 to +0.05" wc static pressure)

Blower Mixer Designation	Capacities (1000's Btu/hr)			Maximum Mixture Pressure (" wc)	Style "A" or "B" LINOFLAME® Burner assembly length (feet-inches of indicated type and drillings)					
	Minimum	On-Ratio Maximum	Rich Maximum		B-36-42-42	B-96-50-50	B-96-44-44	B-96-36-43	A-72-17-33	A-72-C-33
M-100	20	39	50	1.3	1'	8"	4"	3"	---	---
	30	44	70	1.25	1' 3"	9"	6"	4"	---	---
	40	54	120	1.2	1' 6"	1'	8"	6"	---	---
	45	65	130	1.1	2'	1' 4"	1'	8"	6"	---
	60	85	140	1	2' 6"	1' 10"	1' 3"	1'	---	---
	75	98	150	0.75	3' 6"	2' 6"	1' 8"	1' 3"	1'	6"
M-250	80	150	270	1.1	4' 8"	3' 3"	2'	1' 8"	1'	---
	120	180	370	1	6'	4'	2' 8"	2'	1' 6"	---
	175	225	450	0.9	8'	5' 6"	3' 8"	2' 8"	2'	1' 6"
M-500	210	360	600	1.7	10' 9"	7' 3"	4' 9"	3' 9"	2' 6"	1' 9"
	300	500	820	1.6	13' 6"	9' 3"	6'	4' 6"	3' 3"	2'
	310	580	1000	1.5	16' 9"	11' 3"	7' 6"	5' 9"	4'	2' 6"
	475	670	1200	1.4	21' 6"	14' 6"	9' 6"	7' 6"	5'	3' 4"

Capacity/Selection Data

PREMIX® Blower Mixers with INFRAWAVE® Burners

Capacities and necessary burner footage for INFRAWAVE® Burner assemblies used with Type "PM" PREMIX® Blower Mixers are shown in Table 1 below. Follow the maximum capacity column downward until your desired capacity is reached, then read across to the required burner footage and mixer size.

If additional turndown range is required, see Table 2 providing similar information for Type "PH" PREMIX® Blower Mixers which develop slightly higher mixture pressures.

Table 1: Capacities with "PM" PREMIX® Blower Mixer

Mixer Size	Lineal Feet "SG"	Lineal Feet "DG"	Capacity (1000's Btu/hr)	
			Minimum	Maximum
PM-200	1	1/2	10	55
	2	1	20	105
	3	1-1/2	30	150
	4	2	40	200
	5	2-1/2	50	245
	6	3	60	295
	7	3-1/2	65	320
	8	4	72	360
PM-350	7	3-1/2	70	340
	8	4	75	375
	9	4-1/2	83	415
	10	5	92	465
	11	5-1/2	100	510
	12	6	110	540
PM-920	18	9	175	885
	20	10	185	925
	22	11	200	1020
	24	12	215	1110
	26	13	230	1175
PM-2000	24	12	235	1150
	26	13	250	1200
	28	14	260	1295
	30	15	275	1390
PM-3200	32	16	290	1440
	36	18	375	1800
	40	20	410	2000
	44	22	445	2200
	48	24	485	2400

Table 2: Capacities with "PH" PREMIX® Blower Mixer

Mixer Size	Lineal Feet "SG"	Lineal Feet "DG"	Capacity (1000's Btu/hr)	
			Minimum	Maximum
PH-190	1	1/2	10	65
	2	1	16	130
	3	1-1/2	25	195
	4	2	33	260
	5	2-1/2	40	315
	6	3	48	375
	7	3-1/2	55	420
	8	4	60	500
PH-330	7	3-1/2	60	440
	8	4	65	525
	9	4-1/2	75	585
	10	5	82	650
	11	5-1/2	86	675
PH-500	11	5-1/2	92	715
	12	6	100	785
PH-700	12	6	110	800
	14	7	110	845
	16	8	120	960
	18	9	135	1080
	20	10	150	1200
	22	11	165	1280
PH-900	20	10	160	1275
	22	11	170	1320
	24	12	175	1360
PH-1220	24	12	190	1375
	26	13	200	1430
	28	14	210	1475
	30	15	225	1565
	32	16	240	1650
	PH-1650	36	18	270
40		20	300	2200
44		22	330	2420
48		24	360	2640

Dimensions (in inches) Miniature PREMIX® Blower Mixers

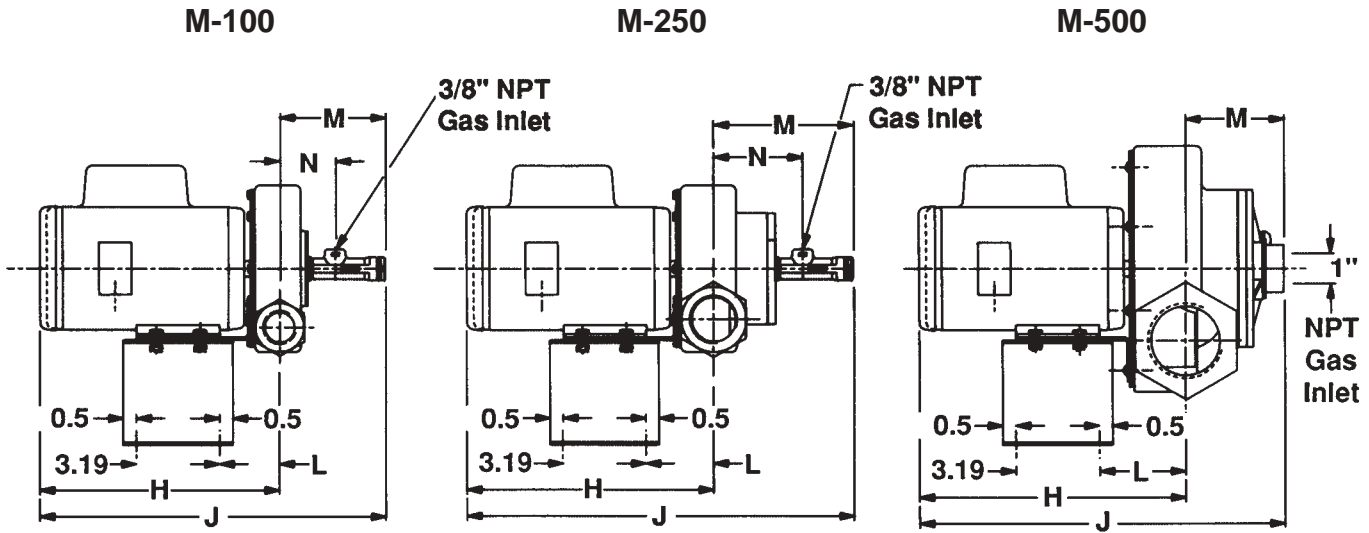

All Sizes

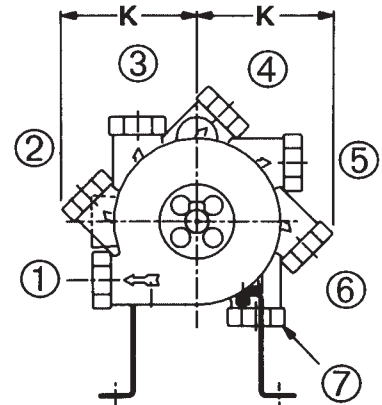
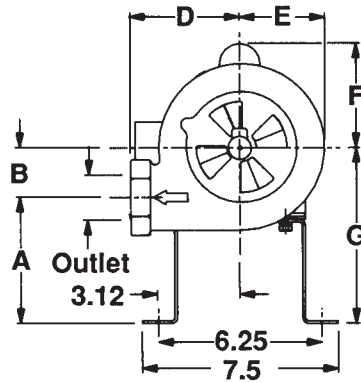
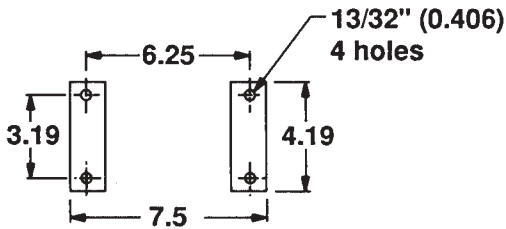

**Available
Discharge Positions**
#1 is supplied unless
otherwise specified

Mini-PREMIX Designation	A	B	Outlet	D	E	F	G	H	J	K	L	M	N
M-100	4.56	2.25	1	4	3.19	3.94	6.75	9.12	13	5.19	2.25	4.06	2.21
M-250	4.81	1.94	1-1/2	4.25				9.44	14.62	5.38	2.56	5.31	3.44
M-500	4	2.75	2-1/2	6.5	4.69	4.69		10.12	13.5	8.19	3.25	3.75	---

Pipe threads on this page conform to NPT (ANSI Standard B2.1)

Dimensions (in inches) "PL" PREMIX® Blower Mixers

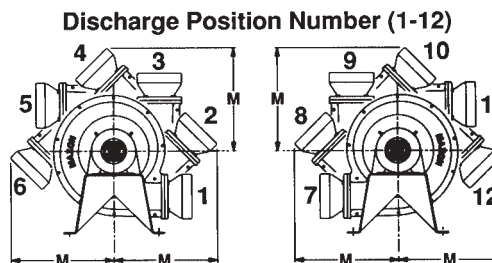
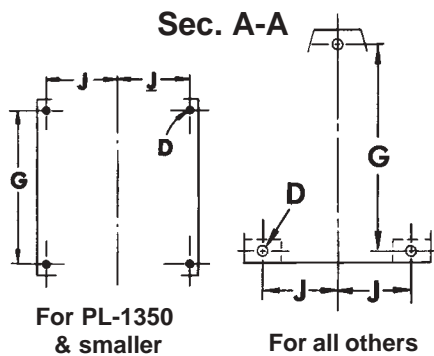
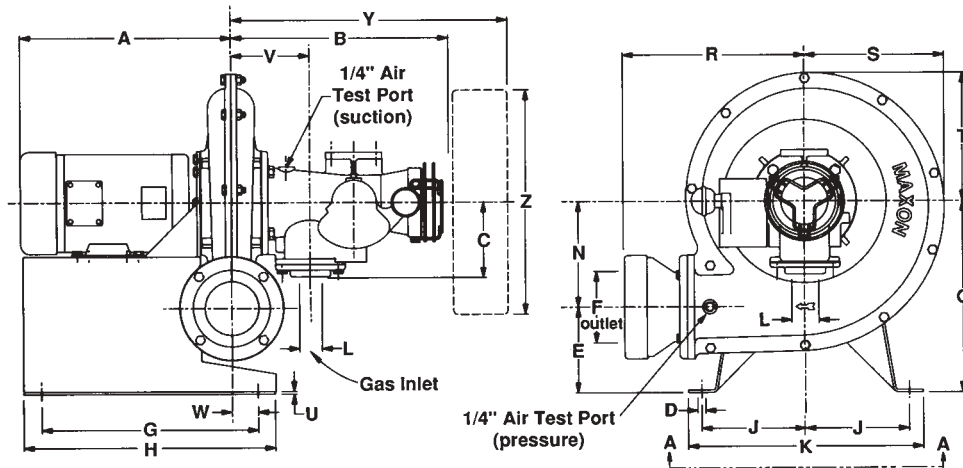

Discharge and ratio valve quadrant position must be specified. Discharge positions 1-6 normally require ratio valve quadrant position "A". Discharge positions 7-12 normally require "B". #1-A discharge is supplied unless otherwise specified.

Dimensions - "PL" Blower Mixers

Mixer	A [1]	B	C	D	E	F size	G	H	J	K	L size	M	N	O	R	S	T	U	V	W	Y	Z
PL-80																						
PL-130	10.88	9.81	4.19	0.44	4.69	1-1/2	11	12.5	4.62	10.5	1	8.12	3.69	8.38	6.31	5.31	5.31	0.12	3.94	2.6	15.25	10.5
PL-165																						
PL-195																						
PL-380	11.12	10.06	4.19	0.44	4.69	2	11	12.5	4.62	10.5	1-1/4	8.88	4.69	8.38	6.31	5.31	5.31	0.12	3.94	2.6	15.25	10.5
PL-490																						
PL-540																						
PL-630																						
PL-750	11.69	12.06	4.19	0.44	4.69	3	11	12.5	4.62	10.5	1-1/4	11.31	5.88	10.62	7.81	7.75	7.19	0.12	3.94	2.6	15.25	10.5
PL-850																						
PL-1000																						
PL-1350																						
PL-1440																						
PL-1700	12.5	11.94	4.19	0.44	4.69	4	11	12.5	4.62	10.5	2	12.81	6.75	12.12	8.44	8.88	8	0.44	3.94	2.6	15.25	10.5
PL-2650																						
PL-3500																						
PL-4250																						
PL-4600																						
PL-4600																						

[1] According to information supplied by motor manufacturer. May vary.

Pipe threads on this page conform to NPT (ANSI Standard B2.1)

Dimensions (in inches) "PM" PREMIX® Blower Mixers

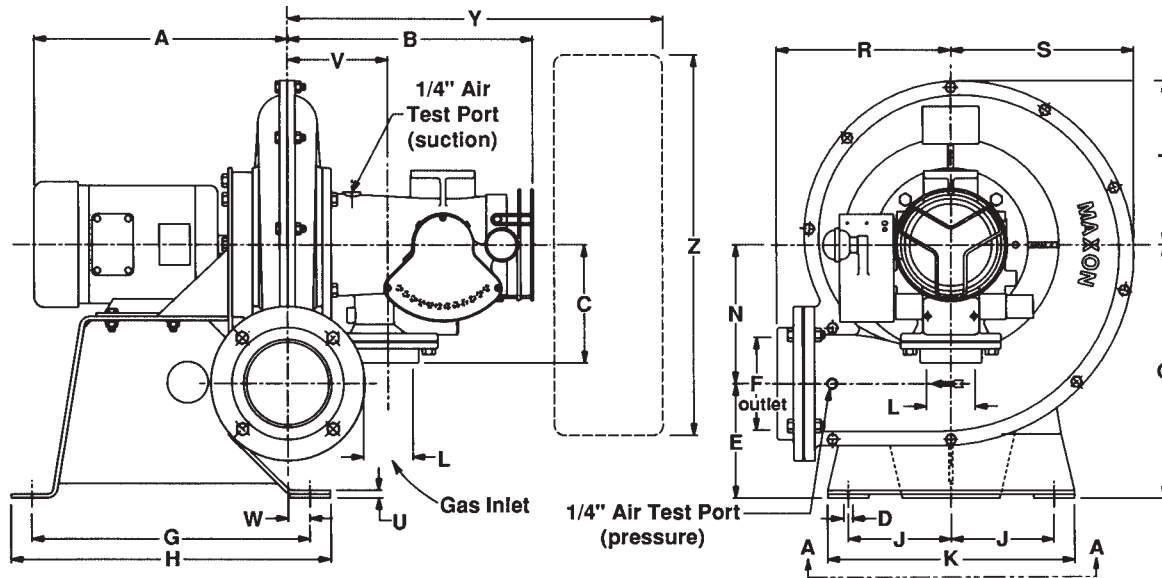

Sec. A-A

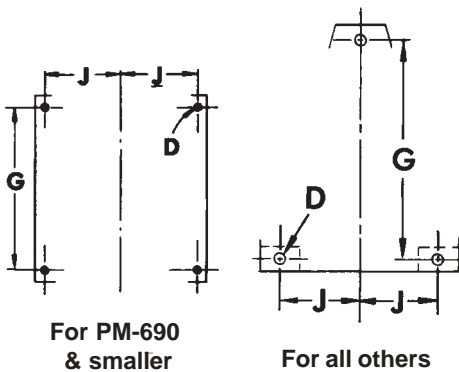

Discharge Position Number (1-12)

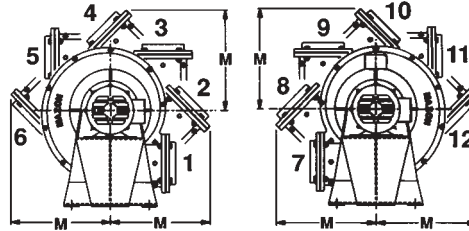

Ratio Valve Quadrant Position (A-B)

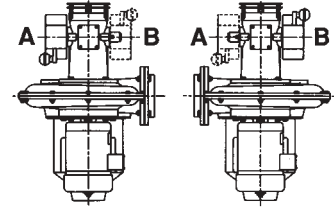

Discharge and ratio valve quadrant position must be specified.
Discharge positions 1-6 normally require ratio valve quadrant position "A". Discharge positions 7-12 normally require "B". #1-A discharge is supplied unless otherwise specified.

Dimensions - "PM" Blower Mixers

Mixer	A [1]	B	C	D	E	F size	G	H	J	K	L size	M	N	O	R	S	T	U	V	W	Y	Z
PM-200																						
PM-260	11.25	10.06			3.69	2	11	12.5	4.62		1-1/4	8.88	4.69	8.38	7.69	6.5	6.5		4.19	1.81	15.5	10.5
PM-350			4.19	0.44						10.5								0.12				
PM-525	11.69	12.06			4.75	3	12	14	5.75			11.31	5.88	10.62	7.81	7.75	7.19		4.38	1.62	15.31	12.5
PM-690	11.12	10.06																	5		18.69	
PM-920			5.75																			
PM-1080	12.5	11.94	4.19		5.38	4	13.5	15.5	6	14	2	12.81	6.75	12.12	8.44	8.88	8	0.44	4.88	1.06	18.06	18.5
PM-1200				0.56																		
PM-2000	15.5	12.44					16.75	18.75				15.06			10.06	10.19	9.22	0.12	5.38	1.12	18.56	
PM-3200	15.88	14	7.12		5.06	6	17.88	19.88	6.5	15	3	15.25	7.94	13	9.62	10.25	9.31	0.44	5.69	1	23.6	23.8

[1] According to information supplied by motor manufacturer.

Pipe threads on this page conform to NPT (ANSI Standard B2.1)

Dimensions (in inches) "PH" PREMIX® Blower Mixers

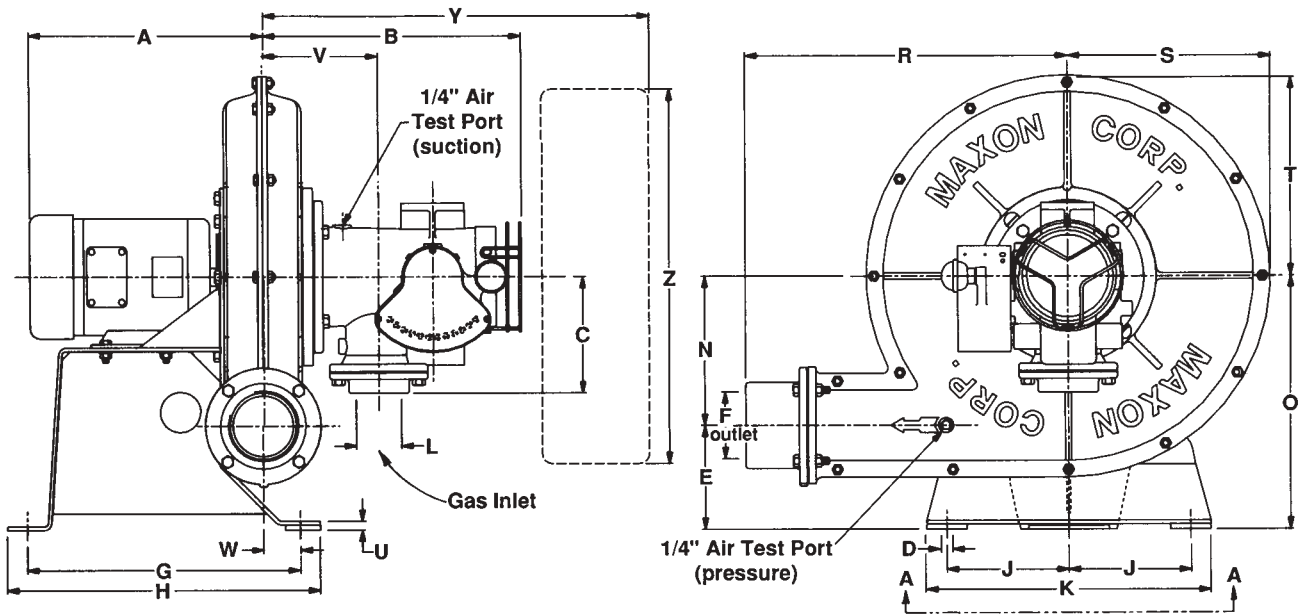

Sec. A-A

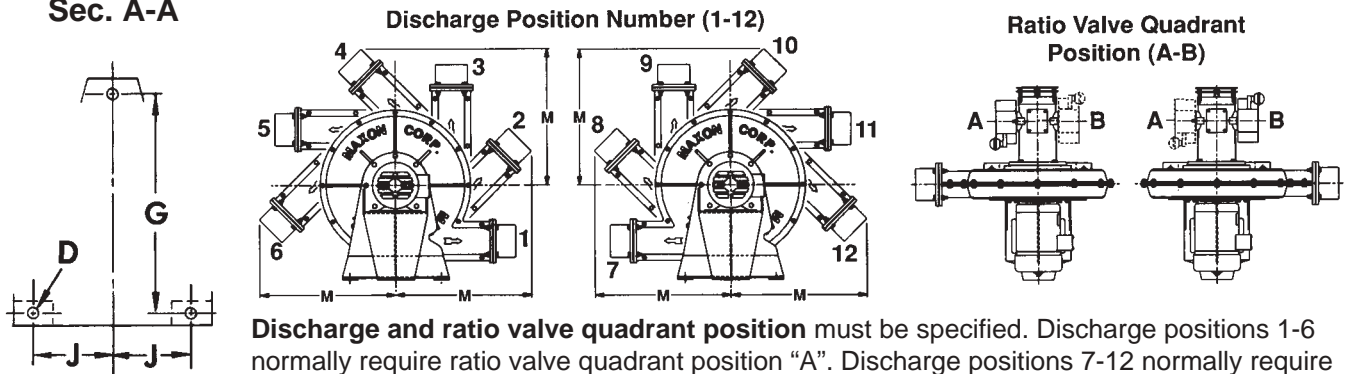

Discharge and ratio valve quadrant position must be specified. Discharge positions 1-6 normally require ratio valve quadrant position "A". Discharge positions 7-12 normally require "B". #1-A discharge is supplied unless otherwise specified.

Dimensions - "PH" Blower Mixers

Mixer	A [1]	B	C	D	E	F size	G	H	J	K	L size	M	N	O	R	S	T	U	V	W	Y	Z	
PH-190	10.31	10.69	4.19	0.56	3.62	2	12.5	14.5	5.5	13	1-1/4	14.75	6.88	10.5	11.69	9	9	0.44	4.81	1.31	15.44	10.5	
PH-250																							
PH-330																							
PH-400	12																						
PH-500																							
PH-700	14.94	12.83																					
PH-900																							
PH-1220																							
PH-1400																							
PH-1650	12.75	5.75				3	13.5	15.5	6	14		17.94		12.5									
PH-2350																							
						4					2	18.75			16.38						18.88	18.5	

[1] According to information supplied by motor manufacturer

Pipe threads on this page conform to NPT (ANSI Standard B2.1)

Accessory Dimensions (in inches)

Stand-by Fuel Arrangement utilizing a Maxon Series "Q" Control Valve is illustrated below and dimensions given in accompanying tables. See Sketch 1 for positions 1-A through 6-A. See Sketch 2 for positions 7-A through 12-A.

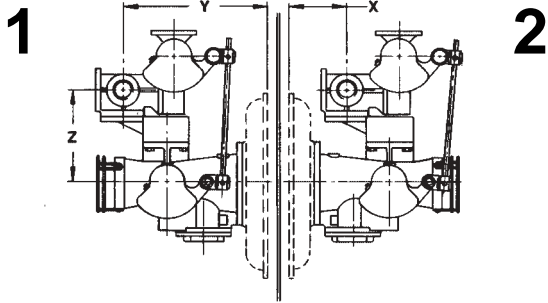

Optional Inlet Air Filter Assemblies are shown in Sketch 3. See tables for dimensions which apply to your mixer size with appropriate filter.

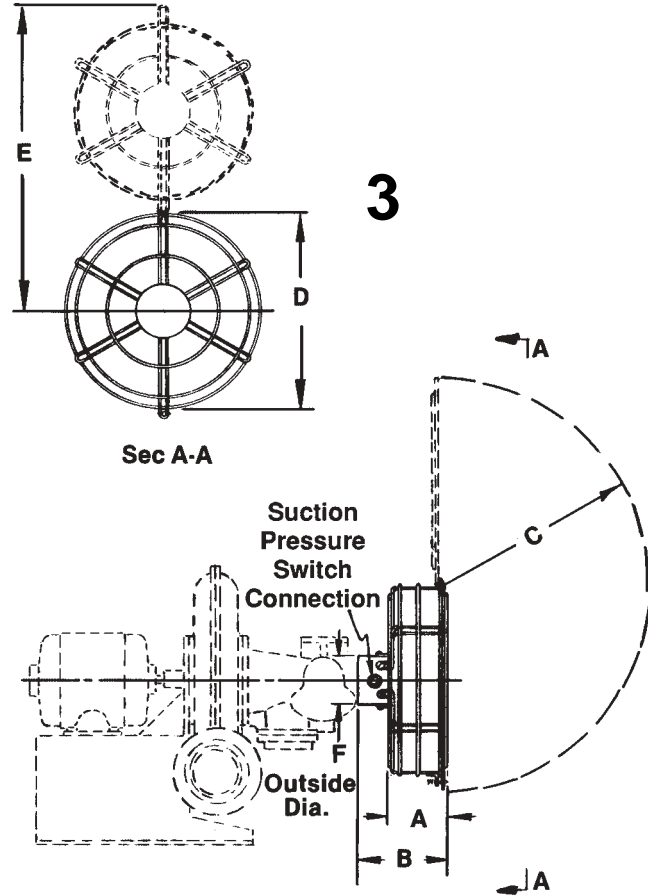

"PL" & "PM" Blower Mixers

Mixer	With "Q" Valve			With Filter Assembly														
	Size	X	Y	Z	A	B	C	D	E	F								
PL-80	1	3.25	9.5	6.56	3.13	7.13	11.5	10.5	16.75	3								
PL-130																		
PL-165																		
PL-195																		
PL-380																		
PL-490																		
PL-540																		
PL-630																		
PL-750																		
PL-850																		
PL-1000	1-1/4	3.69	9.94	7.38	5.06	8.31	18.44	18.5	27.75	5								
PL-1350																		
PL-1440																		
PL-1700																		
PL-2650																		
PL-3500																		
PL-4250																		
PL-4600																		
PM-200																		
PM-260																		
PM-350	1	3.5	9.75	6.56	3.13	7.13	11.5	10.5	16.75	3								
PM-525																		
PM-690																		
PM-920																		
PM-1080																		
PM-1200																		
PM-2000																		
PM-3200																		
PH-190		1-1/4	4.94								11.19	8	7.81	12.31	23.69	23.75	35.56	7
PH-250																		
PH-330																		
PH-400																		
PH-500																		
PH-700																		
PH-900																		
PH-1220																		
PH-1400																		
PH-1650																		
PH-2350	1-1/4	6	12.25	8.38	7.81	12.31	23.69	23.75	35.56	7								

"PH" Blower Mixers

Mixer	With "Q" Valve			With Filter Assembly						
	Size	X	Y	Z	A	B	C	D	E	F
PH-190	1	4	10.25	6.56	3.13	7.13	11.5	10.5	16.75	3
PH-250										
PH-330										
PH-400										
PH-500										
PH-700										
PH-900										
PH-1220										
PH-1400										
PH-1650										
PH-2350	1-1/4	5.25	11.5	7.38	5.06	8.31	18.44	18.5	27.75	5

Component Identification

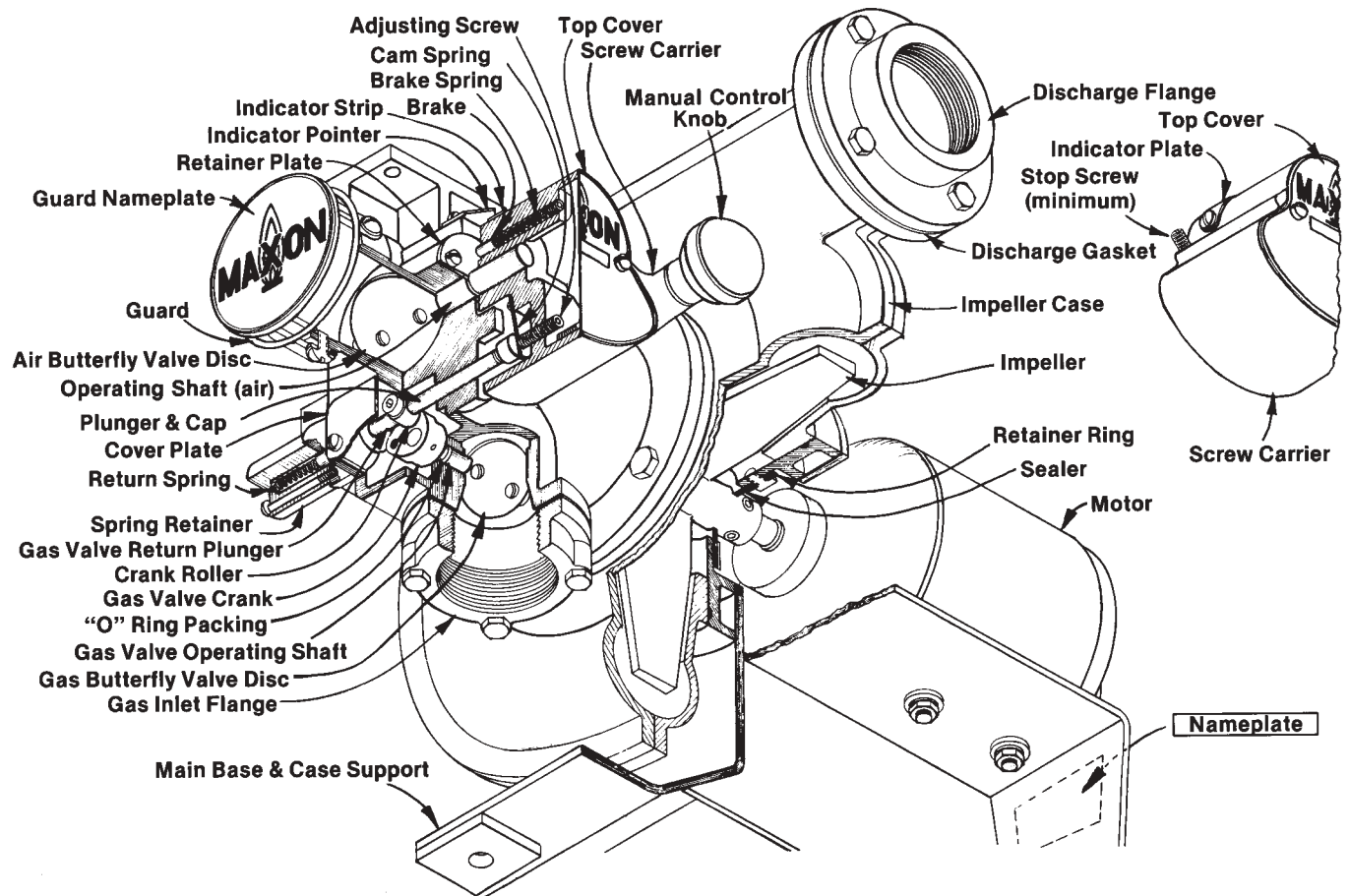

To order replacement parts, specify:

1. Mixer type and assembly number (from nameplate)
2. Part names (from illustration above)
3. Quantity for each

Suggested spare parts:

- Cam springs
- Gas valve plunger and cap

Nameplate



Suggested Maintenance/Inspection Procedures

To replace Air Filter Element

Refer to photo at right, then:

1. Insert finger through each lock ring, then rotate from back to front by pulling against force of spring.
2. Swing hinged cover upward out of the way.
3. Withdraw dirty filter element for cleaning or replacement. If you clean rather than replace filter element, wash in a strong detergent, warm water solution, or steam clean. Dry thoroughly in warm air not to exceed 200°F (93°C) before replacing.
4. Insert new or cleaned filter element into cage. Check that it has extended onto air inlet sleeve providing positive closure at that point.
5. Lower hinged cover to closed position and lock in place with lock rings.

Warning: The filter material used is approved by UL as Class II (fire retardant). Hot welding beads or direct flame can ignite filter material.

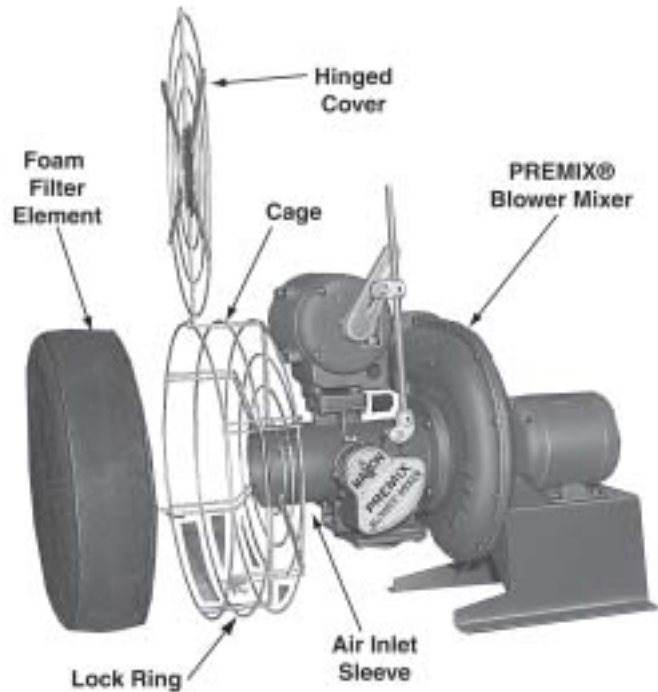

To replace Cam Springs or Plunger & Cap Assembly

Shut system down electrically and close gas cocks, then:

1. Identify components from **Sketches 1 and 2** at right, then remove air filter assembly or inlet cover guard ①, quadrant cover nameplate ②, indicator plate ③, and control motor linkage ④.
2. Rotate quadrant ⑤ counter-clockwise to minimum position. Add an alignment mark across shaft ⑥ and quadrant hub ⑦ as shown in **Sketch 1** if mark does not already exist.
3. Identify brake ⑧ and spring from **Sketch 2** and make a note to avoid losing them when removing quadrant.
4. Insert Allen wrench (provided with replacement cam springs) through holes ⑨ and loosen set screws ⑩, then slide quadrant off shaft carefully.
5. **To replace cam springs**, remove screws ⑪ then lift off and replace with new cam springs and retighten screws ⑪.
6. **To replace plunger and cap assembly** (see component identification drawing on page 3117), grasp cap and lift assembly out of ratio valve. Insert new plunger and cap sub-assembly carefully and check that it slides freely.

7. To re-assemble unit, slide quadrant back over shaft ⑥, taking care that set screws ⑩ line up with and seat properly in the two recesses ⑫ in shaft ⑥. Check that alignment marks match, then tighten set screws ⑩.
8. Replace control motor linkage, indicator plate, quadrant cover nameplate, and inlet cover guard or air filter assembly removed in step 1.
9. Check burner adjustment and refine.
10. Place system back in service.

